



# Video intercom V44 SMART IP System

TOUCH SCREEN MONITOR MANUAL

VIIP-PIT4B

## Table of Contents

<b>GENERAL WARNINGS</b> .....	3
<b>INTRODUCTION</b> .....	4
<b>1 INSTALLATION</b> .....	5
<b>2 DEVICE SIZE</b> .....	5
<b>3 DEVICE CONNECTION</b> .....	5
<b>4 CONNECTING THE FRONT DOOR BELL</b> .....	6
<b>5 MEANING OF THE DEVICE TOUCH BUTTONS</b> .....	6
<b>6 HOME PAGE</b> .....	7
<b>7 DEVICE CONFIGURATION MENU</b> .....	7

## GENERAL WARNINGS

The Purchaser undertakes to handle the packaging with care and to store the material in an appropriate manner, in an environment without humidity and at a temperature not lower than - 5 °C and not higher than + 40 °C.

The Purchaser undertakes to inform its own customers of the storage methods for the material supplied by AVE S.p.A.

The Purchaser undertakes to sell the Products in their original intact packaging. If this is not the case, the Purchaser undertakes to pass on to its customer the instructions for use supplied by AVE S.p.A. with the products. These instructions can also be found in catalogues, technical sheets, brochures, inserts and on the company' s website([www.ave.it](http://www.ave.it)).

In the case of the sale of AVE S.p.A. products in the countries of the European Union, the Purchaser undertakes to check that the instructions for use of the product in the AVE S.p.A. packaging contain the specific language of the country of destination. If this is not the case, the Purchaser undertakes to request AVE S.p.A. to include in the product instructions the language and/or symbols required for the export of the goods, or the Purchaser undertakes to do so on its behalf. If the Purchaser opens the packaging before selling the products, the apparent integrity of the products must be verified; in case of doubt, the products must not be sold.

AVE S.p.A. products are products that require installation. Products and accessories must be installed by qualified personnel. The products must be installed and used in accordance with their intended purpose and in compliance with the standards applicable to the various types of installation, taking into account the provisions of the catalogue, the data sheets and the instructions published on the company's website. In any case, before putting the installed products into service, the system must be tested by authorised personnel to ensure its functionality and compliance with safety regulations in accordance with current legislation.

AVE S.p.A. reserves the right to modify and improve, without prior notice, the products illustrated in its catalogue and listed in the price list, due to the continuous process of productive, technological and regulatory adaptation. The product data sheet or other equivalent documentation is available on request from the AVE S.p.A. Technical Support Service. Consultation of the company's website for updates and confirmation of data is recommended ([www.ave.it](http://www.ave.it)).

### GENERAL INFORMATION

The AVE S.p.A. Video intercom system (Domina Video intercom range) has been designed, tested and approved in accordance with the European standards in force for the installation of electrical systems. For this reason, in addition to complying with the standards in force, it is essential to comply with all the system regulations, from the installation recommendations to the system configuration instructions described in the following paragraphs.

### USEFUL REGULATORY REFERENCES

For the correct implementation of a networked hotel system, we recommend consulting some CEI standards such as:

- [CEI 64-8](#) Electrical system users with a nominal voltage not exceeding 1000 V alternating current and 1500 V direct current
- [CEI 64-55](#) Residential and commercial buildings - Guidelines for the integration of electrical system users and for the preparation of auxiliary, telephone and data transmission installations in buildings - Special criteria for hotels
- [CEI 64-100](#) Residential buildings- Guidelines for the preparation of electrical, electronic and communications infrastructures

### INSTALLATION OF PRODUCTS

This device must be installed in accordance with its intended use and in compliance with all applicable codes, standards and installation regulations. The device must only be installed by qualified personnel. Improper installation or misuse of the device may result in risk of electric shock and/or fire and/or improper operation. Before installation, carefully read the relevant instructions (on the device and in the instruction manual, if available) and consult the technical information available at [www.ave.it](http://www.ave.it). If you believe that you do not have sufficient information for the installation, and/or if you need further clarification, please contact the AVE Technical Support Service on 0039 030 24981 and/or an AVE Customer Support Service (list available at

www.ave.it). Observe the installation and connection procedures and the operating temperatures; before putting the installed products into service, have the system checked by qualified personnel. Do not open, dismantle or alter the product under penalty of forfeiture of warranty and exclusion of liability on the part of the company.

The AVE video-intercom system complies with the strictest product standards both as regards performance and safety requirements and compliance with the relevant environmental tests. It also contains advanced video surveillance functions (which can be activated during installation of the system) that may be subject to Regulation 679/2016 ("GDPR") and the General Provision of the Video surveillance authority of 8 April 2010. Since these indications establish specific obligations for the protection of privacy, we draw attention to the fact that the installation is carried out according to the current laws and legislative decrees on "privacy".

## INTRODUCTION

The purpose of this manual is to guide the installer through the installation of a video intercom system and the subsequent configuration of the parameters necessary for its correct operation. In fact, the rest of this document will outline all the steps necessary for the optimum implementation of a system, starting with the brickwork and the implementation of the electrical system, and ending with an explanation of the meaning of all the icons in the various menus of the management software.

## 1 INSTALLATION

The device should be installed at a height of 1.5 m from the ground.

The VIIP-PIT4B is a wall-mounted device with a mounting plate on a vertically recessed 3-module box. To install the device, screw in the supplied screws to secure the support bracket to the box. Once wiring operations have been completed, align the slots in the back of the monitor with the bracket hooks and slide the device slightly downwards.

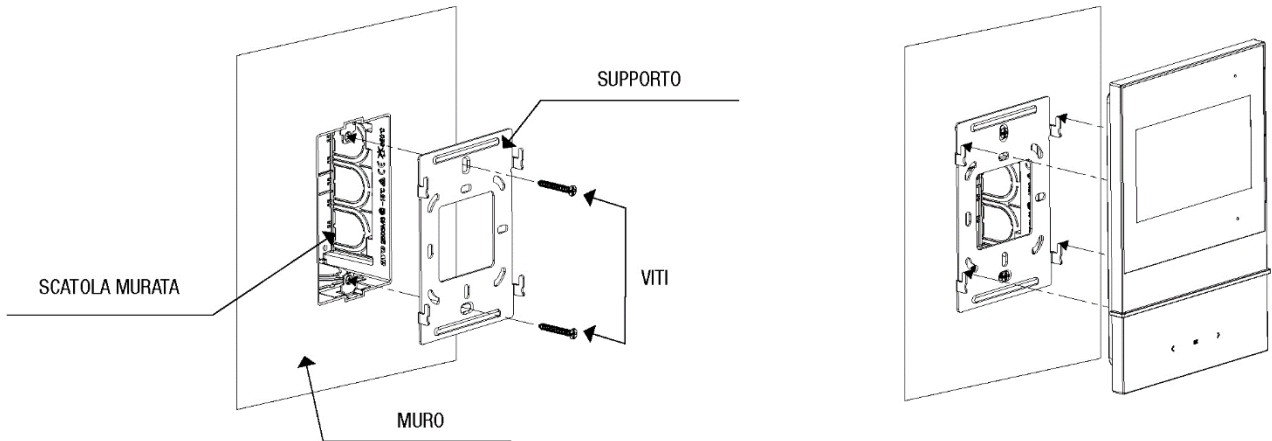

## 2 DEVICE SIZE

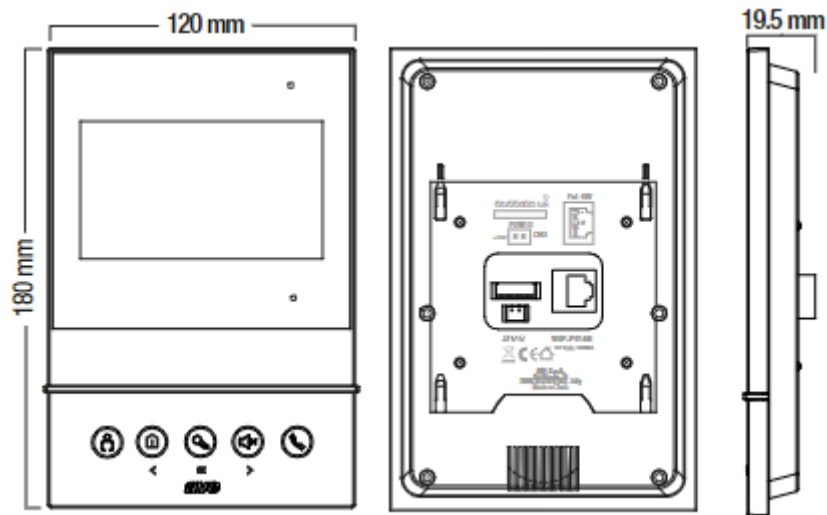

## 3 DEVICE CONNECTION

The VIIP-PIT4B touch screen monitor (indoor station) can be powered in two ways:

- Via a standard PoE 48V<sub>DC</sub> switch
- Via a stabilised 24V<sub>DC</sub> power supply using the special cable supplied with the device by connecting it to connector J4 (check the correct polarity before connecting the connector).

It is not possible to use both power modes simultaneously as this may cause irreparable damage to the device.

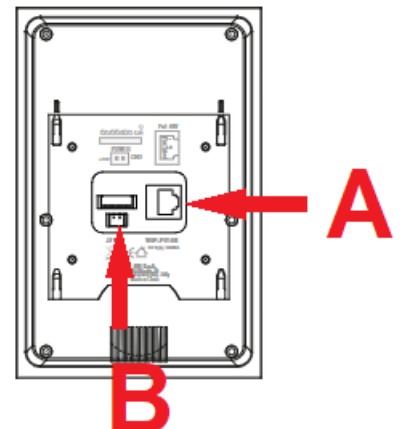



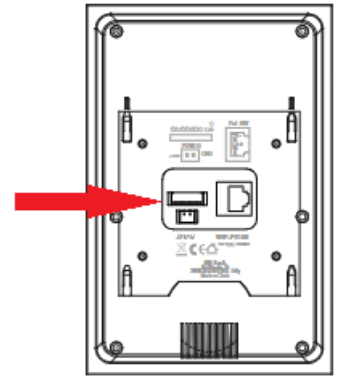

#### 4 CONNECTING THE FRONT DOOR BELL

The devices are supplied with a connector to connect the front door bell. Connect a button with a normally open contact (e.g. item 441001) to the GND (black wire) and Z8 (blue wire) terminals of the pre-wired connector supplied with the device. Pressing the button will cause the touch screen to emit an audible signal.





#### 5 MEANING OF THE DEVICE TOUCH BUTTONS

The meaning of the touch buttons located on the lower section of the device is given below:



					
<b>LCD OFF</b>	Activation of the audio/video communication with the outdoor unit camera (building/villa). When communication has been established, press the button to display the camera of the next outdoor station	Calling the concierge (if present)	LCD switch-on	Muting/un-muting the ringtone. Press and hold to mute/un-mute the ring tone on all indoor units in the flat.	LCD switch-on
<b>LCD ON</b>	Activation of the audio/video communication with the outdoor unit camera (building/villa). When communication has been established, press the button to display the camera of the next outdoor station	Left swipe button	OK button (e.g. confirmation of access to a menu) During a call, it allows: Short press: opening gate 1 Press >3 sec: opening gate 2	Right swipe button	Answering or ending a call











## 6 HOME PAGE

The device is equipped with a colour LCD screen which displays the date and time as well as the five buttons for accessing the various menus.

To access the menus, select the appropriate icon and press the "OK" button. To move within the graphical interface, press the  and  buttons; to confirm your choice, press the  button. The meaning of the menus are illustrated below:

### N.B.

Within all menus, press the  button to save the operation performed and press the  button to cancel the operation.

- **CALLS:** access to the menu allows:
  - a) calling the concierge (if present);
  - b) displaying the camera of outdoor stations;
  - c) making an intercom call within the same flat: select the "Intercom" button to:
    - initiate a call to all indoor stations in a flat. All indoor stations will automatically activate the communication to the calling indoor station;
    - initiate a call to an individual indoor station in the flat. The called indoor station starts ringing while waiting for the user to answer.
  - d) intercom call to different flats. Enter the number of the building and flat to be called and press the  button.
- **CALL LOG:** display of calls made to/received from the indoor station. Press the  button for two seconds to clear the call log. Confirm or cancel the operation by pressing the appropriate buttons shown on the LCD of the device.
- **INFORMATION LOG:** display of any messages sent from the "Concierge" station (if present).
- **SETTINGS:** access to the device settings menu:
  - a) **Languages:** Selection of the language used by the device. Select the desired language and confirm or cancel the operation using the appropriate buttons shown on the LCD of the device; 
  - b) **Time:** select the parameter to be changed using the   buttons and press the  button to make it editable. Press the   buttons to increase or decrease the value of the parameter. Press the  button to confirm the change.
  - c) **Configure:** enter the access password 22222 and confirm the operation by pressing the appropriate button.
    - Flat number:** when programming the system, access the menu to enter:
      - the building:** this is the identification number of the building.
      - the flat:** identifies the progressive number of the flat within a building;
      - the number:** is the progressive number of the indoor station in the flat (e.g. if there is only one indoor station in the apartment, the number to be assigned is 1; if there are two, the first indoor station has address 1 and the second indoor station has address 2);
      - Reset:** resetting the device to default settings. Confirm or reject the operation using the appropriate buttons.
      - Back:** back to previous menu
- **DND:** press the  button to activate/deactivate the "Do Not Disturb" function. When the button is pressed and held, the "Do Not Disturb" function is propagated to all the indoor stations in the flat. The active DND mode is displayed via a special symbol on the home page. 
- **Information:** display of firmware versions installed in the device software versions;
- **Back:** back to previous menu

## 7 DEVICE CONFIGURATION MENU

Power the device via the PoE 48V<sub>DC</sub> switch or via the 24V<sub>DC</sub> switching power supply.







In order for the device to work properly, it is necessary to assign a unique address within the video intercom system.



To do this, access the menu:



**SETTINGS/Configure:** enter the access password 222222 and confirm the operation by pressing the  button displayed on the LCD.

**Then access the menu:**



**Flat number:** enter:



**the building:** this is the identification number of the building. In a single home, the number will correspond to 1, in a building complex (e.g. block of flats) it identifies the progressive number of the building. Select the parameter to be edited with   buttons and press the  button to make it editable. Press the   buttons to increase or decrease the value of the parameter. Press the  button to confirm the change.

**the flat:** identifies the progressive number of the flat within a building. Select the parameter to be edited with the   buttons and press the  button to make it editable.

Press the   buttons to increase or decrease the value of the parameter. Press the  button to confirm the change.

**the number:** is the progressive number of the indoor station in the flat (e.g. if there is only one indoor station in the apartment, the number to be assigned is 1; if there are two, the first indoor station has address 1 and the second indoor station has address 2);

Press the   buttons to increase or decrease the value of the parameter. Press the  button to confirm the change.

Press the  button to confirm the address entered or press the  button to cancel the operation.

#### NOTES:

For the duration and conditions of the warranty for each product, please refer to [www.ave.it](http://www.ave.it) and to the latest sales catalogue. The products must be marketed in their original packaging, otherwise the retailer and/or installer is obliged to apply and forward to the user the instructions accompanying the product and/or posted on [www.ave.it](http://www.ave.it) and in the latest sales catalogue. AVE items are products for installation purposes. They must be installed by qualified personnel in accordance with current regulations and usage, observing AVE S.p.A.'s storage, operation and installation instructions. Compliance with the general terms and conditions of sale, notes, general warnings, warranty warnings, claims and technical warnings for the installer posted on [www.ave.it](http://www.ave.it) and in the latest sales catalogue is also required. **WARNINGS:** Items must be handled with care and stored in their original packaging in a dry location, protected from the elements and at a temperature suitable for storage as indicated in the product manual. If items are not in their original packaging, the dealer and/or installer is obliged to attach and forward the accompanying operating instructions to the user. Storage of items for periods greater than 5 years is not recommended. After opening the packaging, ensure that the item is intact. Installation must be carried out by qualified personnel in accordance with the requirements of the current standard for electrical installations.

The information in this manual may contain technical inaccuracies, omissions or typographical errors. The information contained herein is subject to change or update without notice. AVE S.p.A. also reserves the right to make changes/improvements to the products and/or programs described in this manual at any time and without notice.

**BEFORE INSTALLING SYSTEMS AND AUTOMATIONS, IT IS STRONGLY RECOMMENDED THAT YOU ATTEND A TRAINING COURSE, IN ADDITION TO READING THE INSTRUCTIONS CAREFULLY.**