

Hotel Management

domina Pro
Hotel Management System



Manual 442MBTC-TN



Summary

- 1. General information 3
- 2. General features..... 3
 - 2.1 Mechanical 3
 - 2.2 Installation 3
 - 2.3 Connections 4
 - 2.4 Power, Modbus and Load (M1) 4
 - 2.5 Auxiliary inputs and outputs (M2)..... 4
 - 2.6 Weather conditions 4
 - 2.7 Power supply 4
 - 2.8 Load actuator..... 4
 - 2.9 Electrical durability 4
 - 2.10 Mechanical durability 5
- 3. Functional Performance 5
 - 3.1 Sts LED 5
 - 3.2 Touch Button Assembly (BTN & LED) 5
 - 3.3 Acoustic signal 5
 - 3.4 Transponder Interface 5
- 4. Keypad Connection..... 6
 - 4.1 Activation of termination resistor on Modbus line (SW) 7
- 5. System configuration..... 7
 - 5.1 Creation of access codes 10
 - 5.2 Passage verification (Log) 12
- 6. Reset of the device 14

1. General information

In terms of hardware, the 442MBTC-TN device is a colour touch keypad capable of receiving access codes entered by the user or of reading Mifare cards.

Communication is via Modbus protocol.

The keypad can be used as part of an access control system for small installations in mandatory combination with the 53AB-WBS home automation supervision unit.

2. General features

The characteristics are described with reference to Figures 2.1 and 2.2:



Figura 2.1 Fronte



Figura 2.2 Retro

2.1 Mechanical

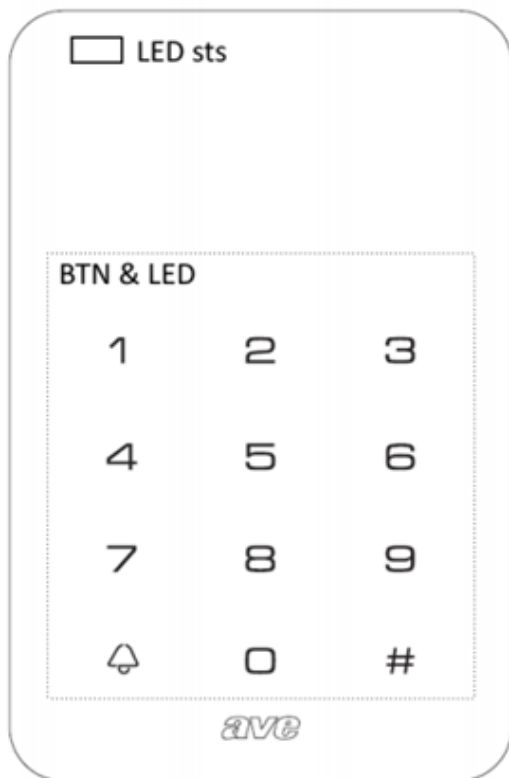
- Product dimensions: 117 x 75 x 22 mm.
- Protection rating: IP40.
- Max. projection from flush power and switching modules: 22mm.

2.2 Installation

The product must be installed against the wall on boxes:

- Masonry: 2501, 2501P, 2502
- Plasterboard: 2501CG

2.3 Connections



Figura 2.3 Morsettiere

- Terminal block M1: PHR-7, removable.
- Terminal block M2: PHR-7, removable.

2.4 Power, Modbus and Load (M1)

- 12V terminal: 12V positive.
- GND terminal: GND (negative).
- 485A Terminal: Modbus RS485 A-line.
- 485B Terminal: Modbus RS485 B-line.
- NC terminal: normally closed potential-free relay contact.
- COM terminal: potential-free common relay contact.
- NA terminal: potential-free relay contact normally open.

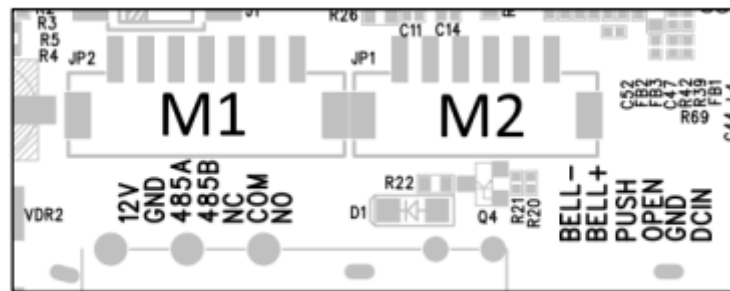
2.5 Auxiliary inputs and outputs (M2)

- BELL- terminal: not in use.
- BELL+ terminal: not in use.
- PUSH terminal: not in use.
- OPEN terminal: input 1.
- GND terminal: input reference.
- DCIN terminal: not in use.

Note: The M2 terminal block is currently not in use. It is therefore recommended not to connect it. The 12V and GND terminals of M1 are common to the GND and DCIN terminals of M2. Isolate the terminals of M2 if connection to the terminal block is still required.

2.6 Weather conditions

- Operating ambient temperature range: 0 °C ÷ + 60 °C.
- Minimum and maximum Relative Humidity range: 20% to 80%.
- Max altitude: 2000 m a.s.l.

2.7 Power supply

- Rated voltage: 12 VDC
- Permitted variation: 10.8 V ÷ 13.2 V.
- Absorption @ 12 Vdc: < 100 mA

2.8 Load actuator

- Ohmic load (cosφ 1): 6A @ 30V AC/DC.

2.9 Electrical durability

- 30,000 operations (NO, 6A, 250VAC/30VDC, resistive load, at 85°, 1s ON 9s OFF).
- 10,000 operations (NC, 6A, 250VAC/30VDC, resistive load, at 85°, 1s ON 9s OFF).

2.10 Mechanical durability

- 10,000,000 operations.

3. Functional Performance

3.1 Sts LED

An optical LED indicator at the top left of the front panel shows the status of the device. The LED is of the RGB type and indicates the status of the device and the result of the access attempt (green if positive, red if negative).

3.2 Touch Button Assembly (BTN & LED)

Group of 12 buttons with different functions based on the operating status of the player. Each button is backlit with an LED. The color of the twelve LEDs can be selected, using a specific configuration mask, with RGB choice. The color of the LEDs is unique for the entire keypad.

During normal operation, the keys have the following meaning:

- buttons 0 to 9: produce, in sequence, the room access code.
- bell button Δ : generates a bell pressed event.
- confirmation button #: converts the sequence of numbers that was entered into a code.

3.3 Acoustic signal

It is used to provide acoustic signals to the user. Typically, it emits a short beep on power-up and a long beep to confirm correct code recognition. In the event of an invalid code, it emits a series of three intermittent beeps for about 1s.

3.4 Transponder Interface

A Mifare interface is available on the device to read ISO14443 (Type A) cards compatible with the hotel system using Modbus readers or AVEBus readers.

This function is currently not in use. It will be implemented from September 2024.

3.5 Response times

The maximum time interval between entering a code on the keypad and the actual actuation of the relay (or rejection of the code) is:

- n°5 art. 442MBTC-TN: 800 msec
- n°10 art. 442MBTC-TN: 1.3 sec
- n°15 art. 442MBTC-TN: 1.8 sec

4. Keypad Connection

In terms of hardware, the device is a colour touch keypad capable of receiving access codes entered by the user or of reading Mifare cards. In terms of detail, the main hardware elements are as follows:

- 12-key touch keyboard with 10 numeric keys (0-9), bell key, acknowledgement key (#), configurable RGB LEDs.
- HF41F5Z8STG NO 250VAC/30VDC Relay - 6°.
- Mifare Classic antenna.
- Status LED.
- Three-wire A-B-GND RS485 serial interface.
- Optional jumper for enabling 120 Ohm termination resistor. On the keypad, where the bus connection ends, the switch on the back of the keyboard (above the connector) must be set to ON.

In terms of logic and communication, the device is a MODBUS RTU SLAVE on a three-wire RS485 transmission medium. Each device has a different Modbus address and, according to the Modbus standard, only writes on the RS485 bus in response to requests from the master. The figure below schematically illustrates the typical architecture of device use.

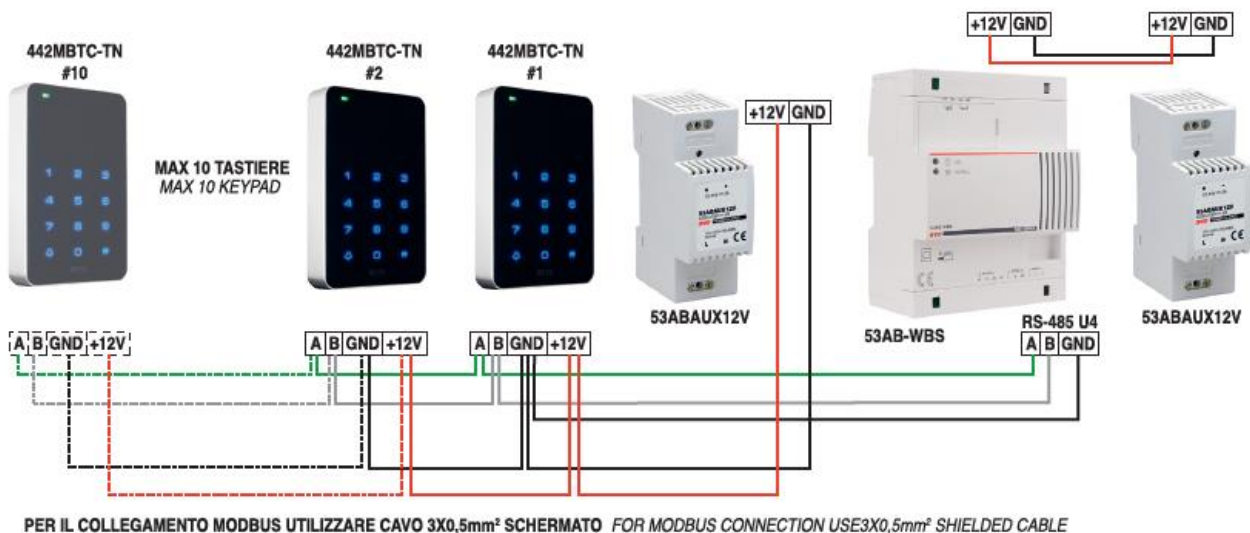
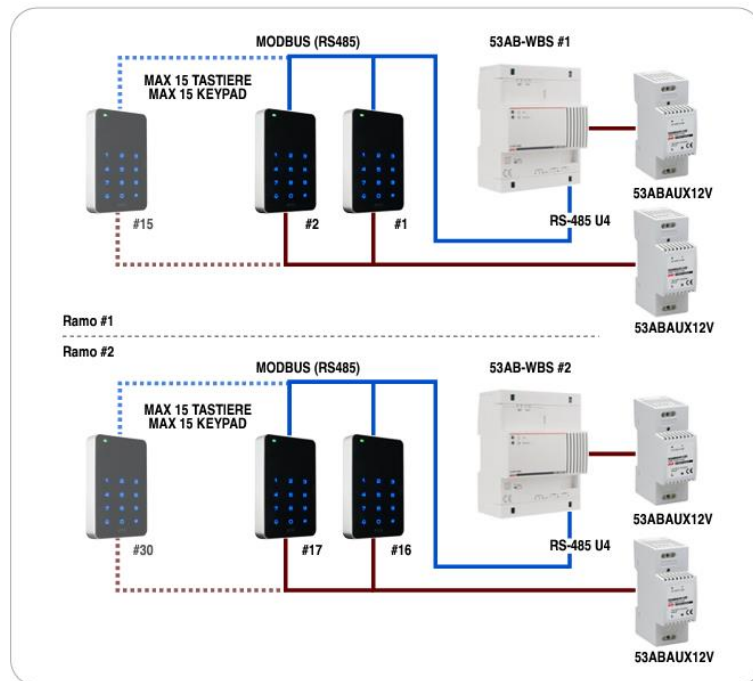

In detail, the connection of each keyboard will be:

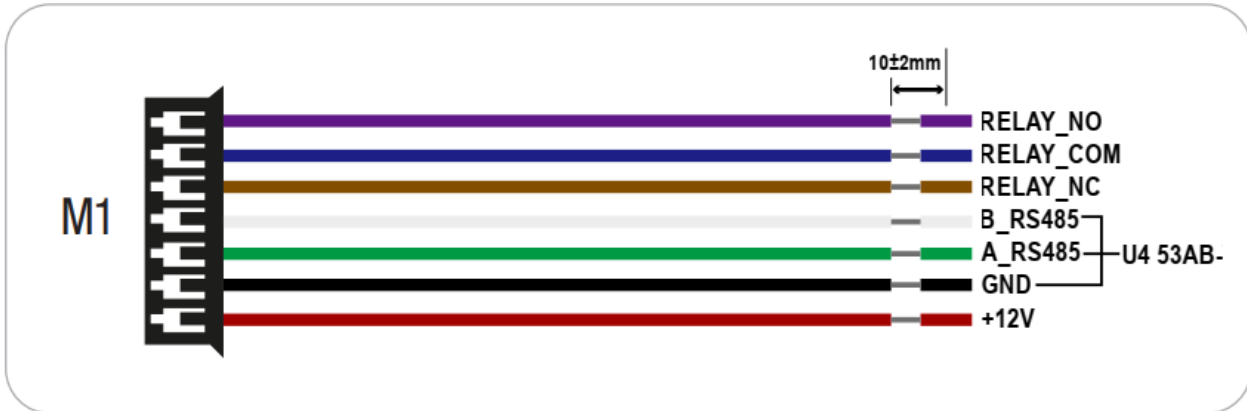

Note: as can be seen in the figure above, the negative terminal of the power supply is common to the GND of the RS485 signal. Simply connect the negative terminal of the 53AB-AUX to the GND terminal of input U4 (53AB-WBS).

The CVAVEBUS cable is recommended for connecting keypads.

Up to 15 keypads can be connected to each 53AB-WBS web server.

4.1 Activation of termination resistor on Modbus line (SW)

Accessible on the back side of the product, adjacent to the input terminals, there is a switch to enable the 120 Ω termination resistor in parallel to the Modbus line.

For the correct functioning of the system it is necessary to terminate the last device of the Modbus line by placing the dip switch J1 in the "ON" position.

5. System configuration

Once the connection has been made, the Modbus address must be assigned to the keypad. When a device leaves the factory, it has no Modbus address assigned and RS485 communication is therefore disabled. In this state, the status LED on the top left of the device flashes red three times in succession, followed by a one-second pause. In this condition, the device is waiting for a sequence of 6 numbers followed by the confirmation key '#'. This sequence must be in the form:

0-0-0-X-Y-Z-...

Where XYZ represent the Modbus slave address. The accepted values according to the standard are 1 to 247. The success of the operation is indicated by a long beep and a single flash of the Status LED, which has now turned green.

A few examples are given:

0	0	0	0	0	1	#	Indirizzo valido 1
0	0	0	0	1	5	#	Indirizzo valido 15
0	0	0	1	2	3	#	Indirizzo valido 123
0	0	0	2	4	7	#	Indirizzo valido 247
0	0	0	0	0	0	#	Indirizzo non valido
0	0	0	2	5	0	#	Indirizzo non valido

Next, go to 'EasyConfig' on the supervisor's web interface and click on the 'NON AVEBUS DEVICES' button and then on the 'ACCESS CONTROL KEYPAD' button, as shown in the screenshots below.



You are then redirected to the local system project section, from which it is possible to:

1. Display the list of Modbus keypads in the system with their address and description.
2. Add a new keypad.
3. Delete an existing keypad.
4. Modify an existing keypad.
5. Carry out an opening test of the relay on board a specific keypad.
6. Display real-time statistics of Modbus communication.

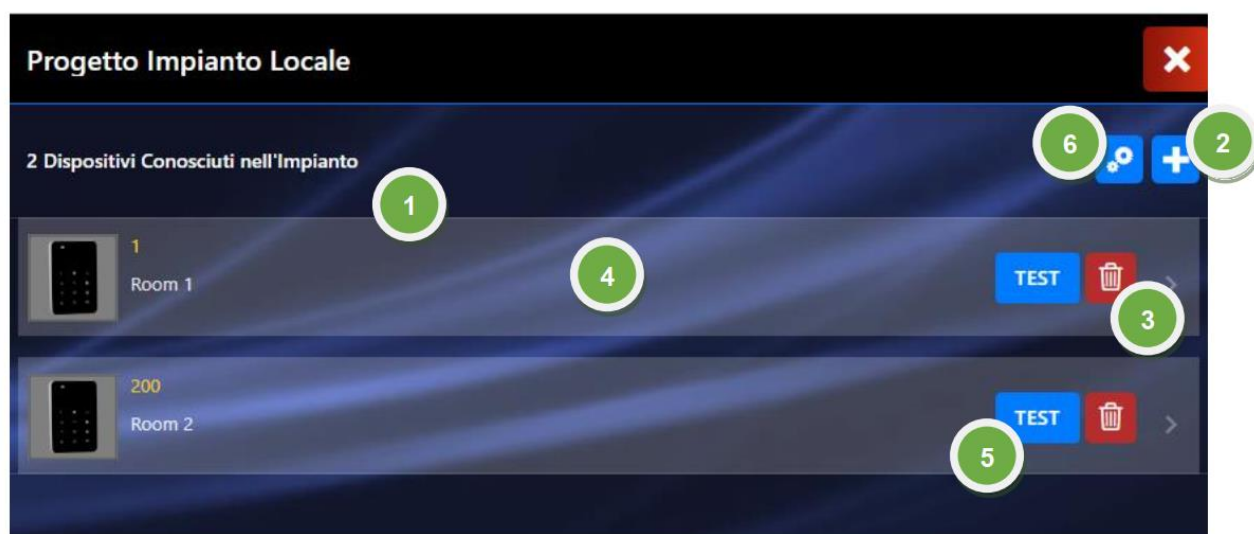

To add a new device, click on the '+' button and select the keypad model to be added to the system.

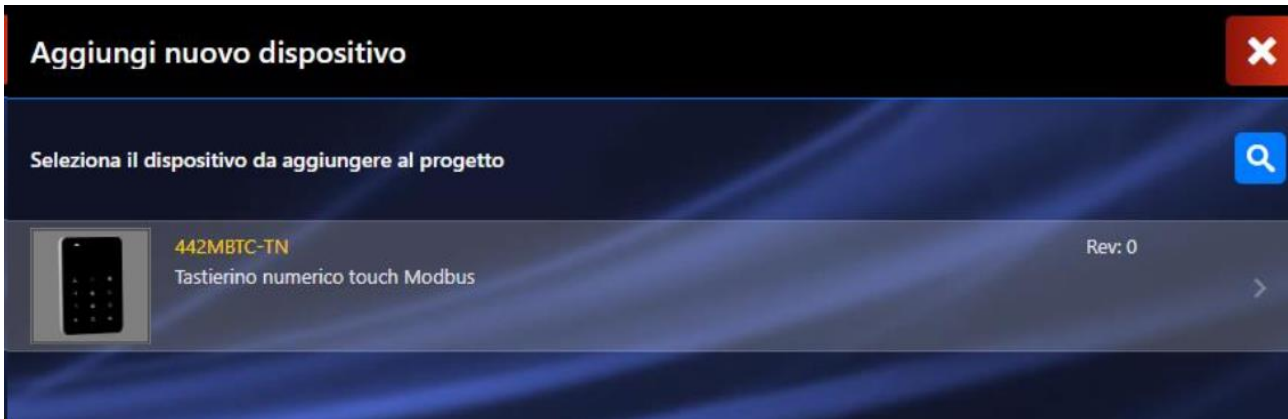

The configuration parameters of the keypad model 442MBTC-TN are:

1. The Modbus address (enter the same address configured manually on the keypad).
2. The ON time of the relay on the keypad activated by a valid code.
3. The colour of the key backlighting (RGB).
4. A description of the keypad (e.g. the number of the room where it is located).

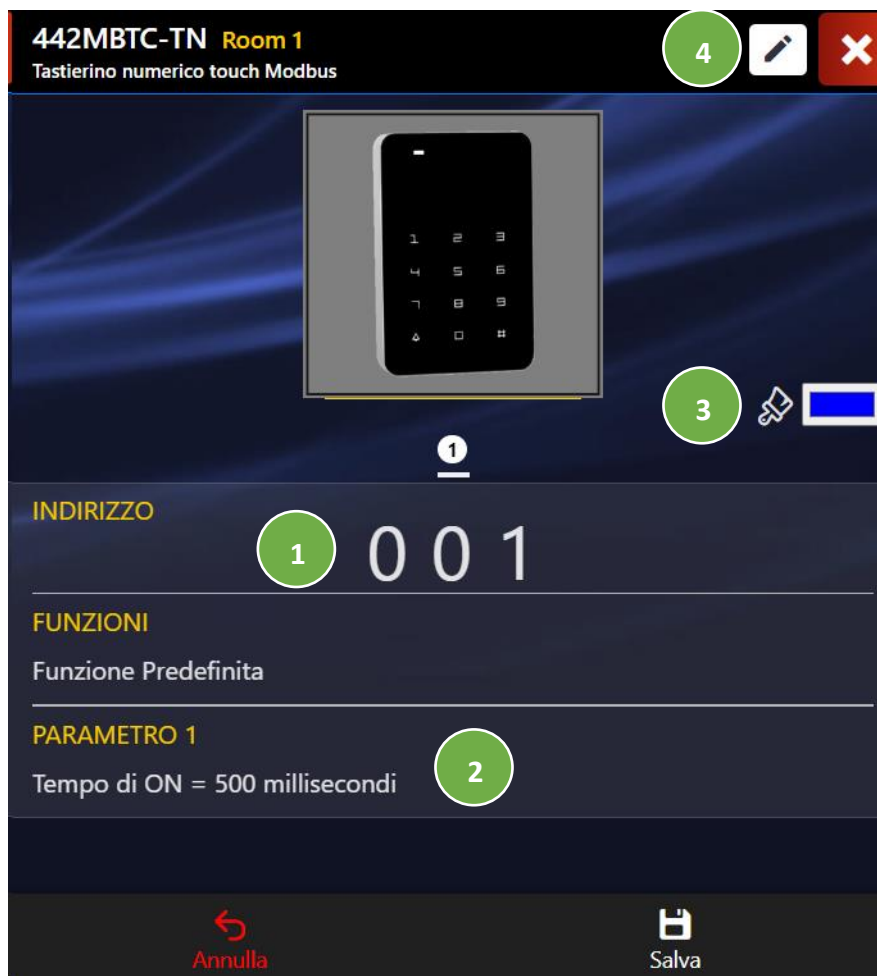

5.1 Creation of access codes

Once the system has been configured, one or more valid access codes must be specified in order for a keypad to open the lock via the on-board relay.



To view existing keypad-code associations and add new ones, the user must first click on the cogwheel (1) from the main screen, then enter the 'Access Control' section (2) and then click on the 'Manage Keypads' button (3):

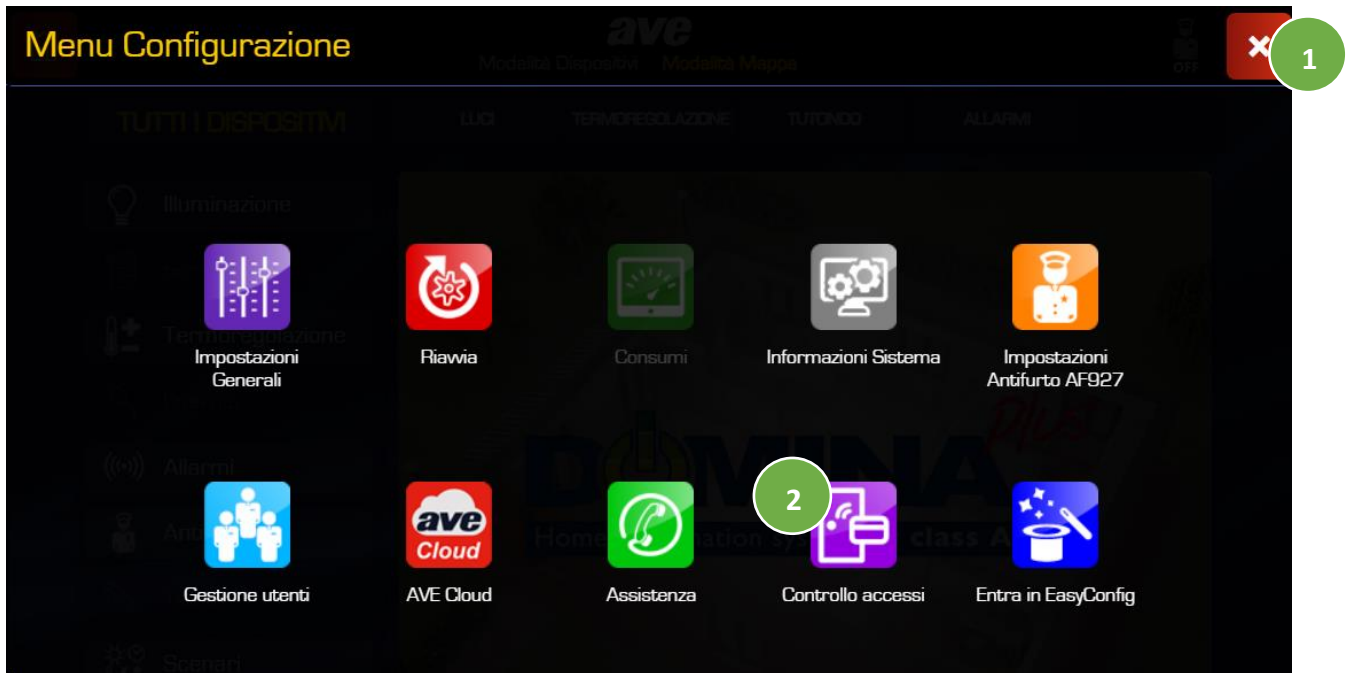

This section shows the keypads in the system and the codes associated with them which authorise the opening of the lock.

There are two views of the page, which can be selected by clicking on the column name:

1. View for 'Door Opener Keypads':
for each keypad (left column) all the codes authorised to open the same keypad (right column) are grouped together, with the possibility of deleting the individual code-keypad association without completely eliminating the code that may still be present on other keypads or that may be reused in the future.

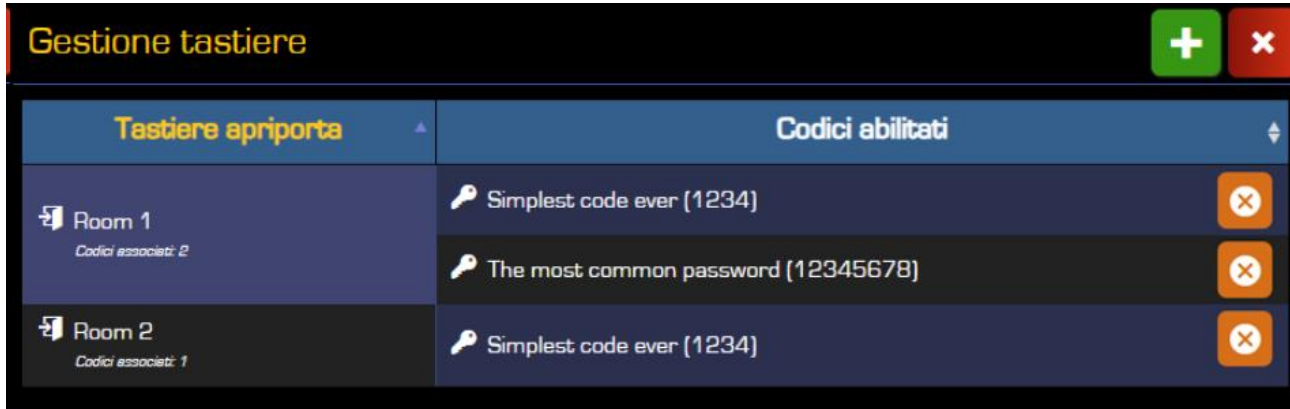

2. View for 'Enabled Codes':
for each code (right column), all the keyboards that can be opened with this code (left column) are grouped together, with the possibility of completely deleting a single code and all its associations, or modifying the description and associations of an existing code.

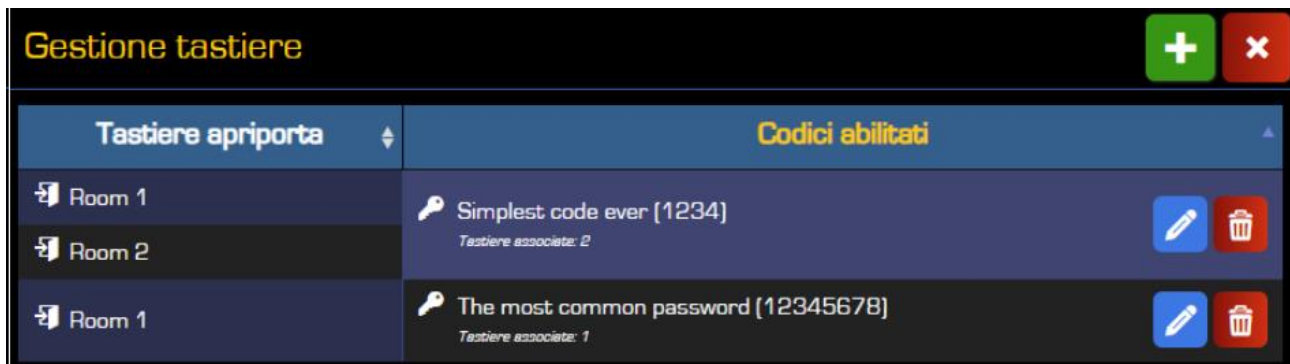

By pressing the '+' button, a new code can be generated. Creating a new code involves entering the following information:

1. Numeric key: code of up to 8 digits; the '4 digits' and '8 digits' keys generate a random code of 4 and 8 digits respectively.
2. Description: optional field that allows the hotelier to associate the code with a description, such as the customer's name.
3. Associated keypads: multiple selection of keypads enabled to open when this code is entered.

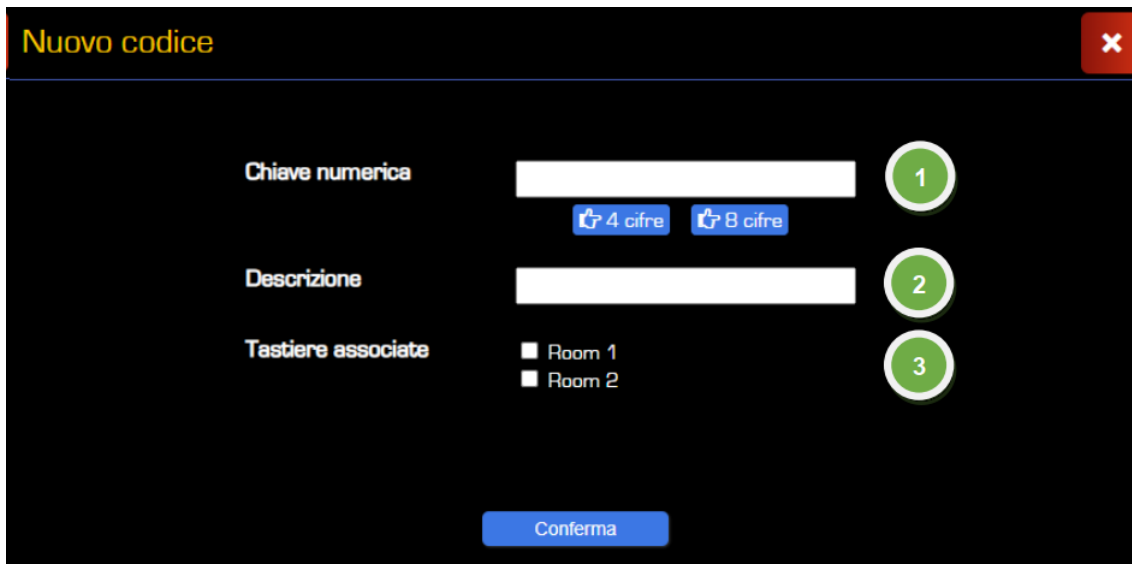

Once the code has been generated, it is necessary to enter the numerical sequence and press the # key to access the gate.

5.2 Passage verification (Log)

The 53AB-WBS supervisor configured as Modbus Master of the keypads makes it possible to create a log of all accesses (or access attempts) made on each device.

To access the log file, simply connect to the supervisor's web interface and enter the 'Access Control' section:

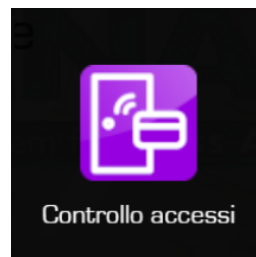

The access logs are displayed in the form of a table, where each row represents an access attempt with the following information:

- The result of access, indicated by a green open padlock if positive, or a red closed padlock if negative.
- Date and time of the access attempt.
- The code entered.
- The description of the code (if entered by the hotelier).
- The description of the keypad on which the code was entered.

Controllo accessi ✕

Gestione tastiere

AutoRefresh
 15/11/2023 12:24

	Data e ora	Codice/UID	Descrizione	Dove
CODE KEYPAD	15/11/2023, 12:24:30	00012345	–	Room 1
CODE KEYPAD	15/11/2023, 12:24:14	00564128	–	Room 1
CODE KEYPAD	15/11/2023, 12:24:00	12345678	The most common password	Room 1
CODE KEYPAD	15/11/2023, 12:22:14	00001234	Simplest code ever	Room 1

← 1 →

6. Reset of the device

The device can be restored to the factory parameters by carrying out the following procedure:

With device turned on:

- Make a bridge between the GND and SDA pins of the CON1 connector
- Keep the bridge closed for approximately 10 seconds
- The device will emit a sound confirmation (beep) to confirm the deletion
- Disconnect the bridge

