

Divisione **Sicurezza** **Safety Security** Division



Antintrusione

Anti-intrusion

Attraverso centrali miste filo/radio è possibile proteggere nel modo migliore ogni tipologia di edificio. Le centrali sono perfettamente integrate con il sistema domotico AVE "Domina Smart": l'utente potrà sperimentare i vantaggi che derivano dall'unione tra i sistemi di sicurezza e la domotica.

The hybrid wired / wireless central units are the best systems to protect any kind of buildings. The central units are perfectly integrated with the home automation system AVE "Domina Smart": the user can experience the benefits that result from the combination of the security systems and home automation devices.

Dispositivi via filo
Wired devices



RADIO

Dispositivi via radio
Radio devices



612



Allarmi tecnici

Technical alarms

Rivelatori di gas (metano e GPL) e relativi accessori.

Gas detectors (natural gas and LPG) and related accessories.

633



Rivelazione incendio

Fire detection systems

Attraverso centrali miste filo/radio è possibile proteggere nel modo migliore ogni tipologia di edificio. Le centrali sono perfettamente integrate con la gestione alberghiera "Domina Hotel" ed il sistema domotico AVE "Domina Smart": l'utente potrà sperimentare i vantaggi che derivano dall'unione tra i sistemi di sicurezza antincendio e la domotica.

You can better protect each type of building through mixed wired/wireless central units. The central units are perfectly integrated to hotel automation "Domina Hotel" and to the home automation system AVE "Domina Smart": the user can experience the benefits that arise from the interaction between fire detection security systems and home automation.

634



Apparecchi per l'emergenza

Emergency devices

Lampade di emergenza da incasso e da serie civile coordinate con i sistemi 44 e 45 che consentono di rimanere in completa sicurezza in caso di black-out elettrico.

Wall mounted, flush mounted and emergency lamps that allow you to stay in complete safety in case of a power failure. The flush mounted lamps match the wiring accessories of system 44 and 45.

644



KIT

Dispositivi antintrusione via radio e via filo venduti in Kit.

Wired and wireless anti-intrusion devices in Kit version.

697





Antintrusione

Anti-intrusion

Vista d'insieme del sistema DOMINA Radio/Filo
DOMINA Wired/Radio system overview

612

Moduli espansione bus filare Wired bus expansions



AFEX6I-REN
Modulo remoto espansione
a 6 ingressi
*Remote module expansion
with 6 inputs*

Centrali antintrusione Anti-intrusion control units



Sirene radio o filari Radio and wired sounders



AF53903R-DB
Sirena radio dual band con
messaggi vocali
*Wireless siren dual band with
vocal messages*



AF53900N
Sirena filare
Wired siren

Rivelatori perimetrali Perimeter detector



AF915R-DB
Rivelatore perimetrale via radio
da interno
*Radio perimeter detector for
indoor*



AF965R-DB
Rivelatore perimetrale via radio da
esterno (riparato)
*Radio perimeter detector for outdoor
(sheltered)*

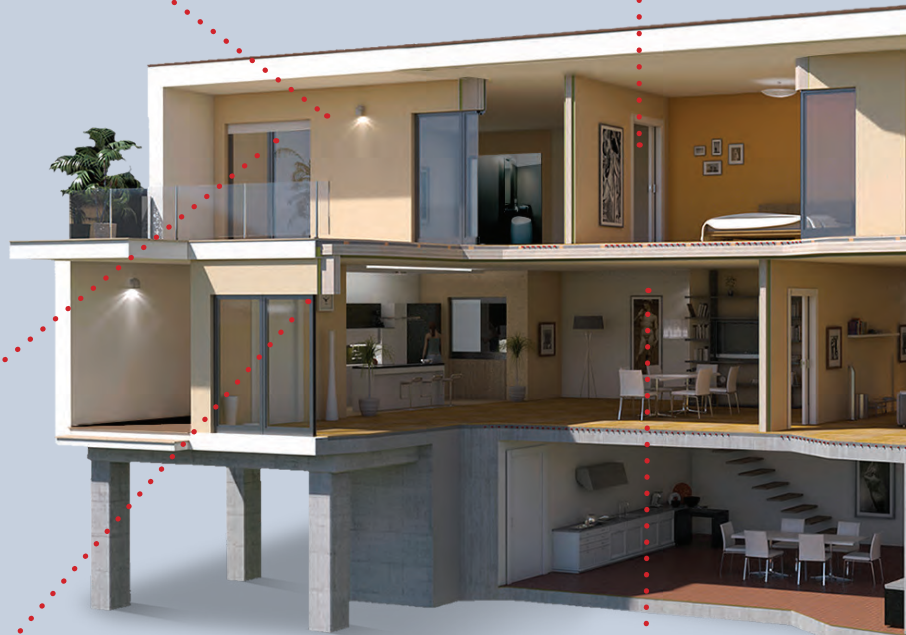

Rivelatori volumetrici da interno Volumetric internal detectors



AF963R-DB
Rivelatore PIR via radio
PIR radio detector



AF963N
Rivelatore volumetrico doppio PIR
Dual technology detector



Attenzione:
è consigliata l'installazione di un limitatore di sovratensione per prevenire danni all'impianto in caso di scariche atmosferiche e sovratensioni degli impianti (vedi apposita sezione del catalogo).

Warning:
the installation of a surge protection device is recommended to prevent damage to the system in the event of atmospheric discharges and overvoltages of the systems (consult specific section of the catalogue).

Monitor gestione impianto Plant management monitor



VI2F-PIT7WF



TS-SMART18ALS
TS-SMART18ANS



TS-SMART10ALS
TS-SMART10ANS



TS-SMART7ALS
TS-SMART7ANS



TS01



Gestione remota Remote control



Telecomando Remote control



AF943R
Telecomando a
4 pulsanti.
4 push buttons
remote control.



Tastiera filare Wired keyboard

AF990
Tastiera filare
Wired keypad



Tastiera radio Radio keypad

AF970R-DB
Tastiera radio
Radio keypad



Rivelatori da esterno Outdoor detectors

AF964R-DB
Rivelatore da esterno doppio PIR + Microonda
via radio Dual Band e bidirezionale
Dual PIR + Microwave via radio for outdoor use
detector via Dual Band and bidirectional radio

AF976R-DB
Rivelatore da esterno effetto tenda doppio PIR via
radio Dual Band e bidirezionale
Double PIR outdoor detector via radio - curtain
effect - dual band and bidirectional for outdoor use

AF974F
Rivelatore volumetrico di movimento a triplo
sensore: doppio PIR e microonda
Triple-sensor volumetric motion detector: double
PIR and microwave



Ripetitori di segnale

AFTRA03
Ripetitore di segnali
radio dual band
Dual band radio signal
repeater

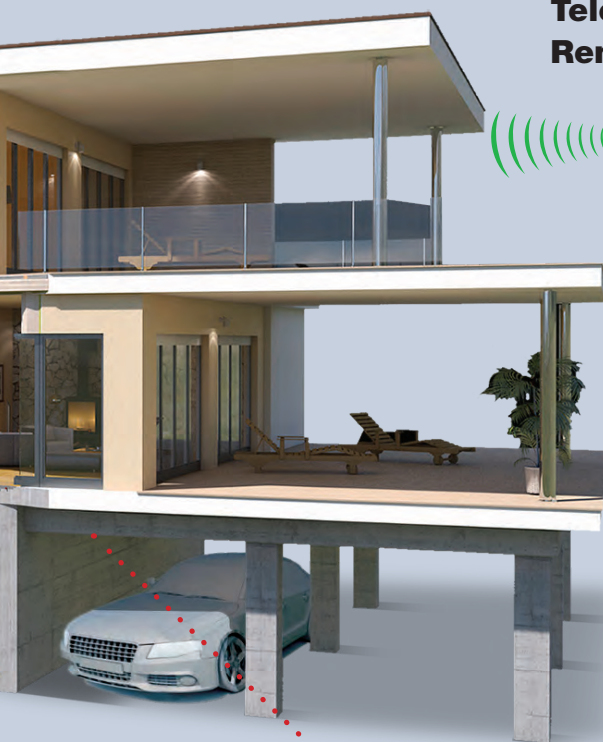

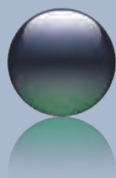

Antintrusione

Anti-intrusion

Tabella riepilogativa gamma AF927 AF927 range summary table



614

Caratteristiche Tecniche Technical Features

Codice / Code	Descrizione / Description	Note / Notes
AF915R-DB	Rivelatore perimetrale radio dual band colore Bianco <i>Radio perimetral detector dual band white</i>	Gestisce in modo indipendente 1 contatto magnetico (incluso) e n.2 ingressi filari tramite morsettiera a bordo del dispositivo. Doppio reed di cui uno per funzione tamper magnetico. Batteria: 1xCR123 inclusa. <i>It manages independently 1 magnetic contact (included) and 2 wired inputs connected to onboard terminals. Double reed one of which for magnetic tamper function. Battery: 1xCR123 included.</i>
AF915R-MDB	Rivelatore perimetrale radio dual band colore marrone <i>Radio perimetral detector dual band brown</i>	
AF927PLUS	Centrale radio e filo <i>Radio/wired control unit</i>	Periferiche gestite n.120 totali da selezionare tra: 99 radio + n.8 filo (16 con funzione double) + n.120 su BUS filare. Alimentatore interno 1,6A. Da completare con n.2 batterie AF911 (12V, 1,8Ah) <i>Peripherals managed total to be selected from: 99 radio + 8 wire (16 with double function) + 120 on wired BUS. Internal power supply 1.6A. To be completed with n. 2 batteries AF911 (12V 1,8Ah)</i>
AF927PLUSTC	Centrale radio e filo con Touch screen a colori da 7" <i>Radio/wired control unit with 7 inches touch screen</i>	
AF927INTFIL	Interfaccia per bus filare <i>Wired bus interface</i>	Consente il collegamento e la gestione delle periferiche su bus filare. <i>It allows connection and management of peripheral devices on a wired bus.</i>
AF927INTLAN	Interfaccia LAN <i>LAN interface</i>	Consente la connessione delle centrali alla LAN cablata. <i>It allows the connection of the control panels to the wired LAN.</i>
AF943R	Telecomando radio bidirezionale <i>2-Way radio remote</i>	6 funzioni disponibili - gestione n.2 scenari domotici AVEBus. Numero massimo 32 per impianto. Batteria: 1xCR2032 inclusa. <i>6 functions available - management of 2 AVEBus home automation scenarios. Max n.32 for plant Battery: 1xCR2032 included.</i>
AF963R-DB	Rivelatore PIR radio dual band <i>Dual band radio PIR detector</i>	Trasmissione in doppia frequenza. Batteria: 1xCR123 inclusa. Disponibile snodo AF961N <i>Dual band transmission. Battery: 1xCR123 included. AF961N joint available</i>
AF964R-DB	Rivelatore da esterno 2 PIR + MW <i>2 PIR + MW outdoor detector</i>	Trasmissione in doppia frequenza. Batterie 2xCR123 incluse. Disponibile snodo AF964R-DBS. <i>Dual frequency transmission. 2xCR123 batteries included. AF964R-DBS joint available.</i>
AF965R-DB	Rivelatore radio dual band con doppio sensore pir, effetto Tenda <i>Dual band radio detector with double pir sensor, curtain effect</i>	Controllo dell'attraversamento dei due fasci selezionabile: entrambi i fasci - solo un fascio dall'esterno verso l'interno. Batteria: 1xCR123 inclusa. <i>Selectable check of 2 beams crossing: both beams - only one beam outside to inside. Battery: 1xCR123 included.</i>
AF970R-DB	Tastiera radio multifunzione dual band <i>Two way multifunction radio keypad</i>	LCD retroilluminato. Lettore tag a bordo. Batteria CR123 inclusa. <i>Backlit LCD. Tag reader on board. CR123 battery included.</i>
AF976R-DB	Rivelatore effetto tenda doppio PIR via radio Dual Band e bidirezionale da esterno <i>2 PIR radio detector curtain effect - dual band and bidirectional for outdoor use</i>	Rivelatore ad effetto tenda long range. Batterie 2xCR123 incluse. Disponibile snodo AF964R-DBS. <i>Long range curtain effect detector. 2xCR123 batteries included. AF964R-DBS joint available.</i>
AFGSM04-4G	Modulo GSM 4G <i>4G GSM module</i>	Consente la gestione completa delle centrali da remoto, l'invio di messaggi SMS e le chiamate vocali. Assorbimento in stand by 20mA, in chiamata ~300mA <i>It allows the complete management of the control panels remotely, the sending of SMS messages and voice calls. Absorption in stand by 20mA, in call ~ 300mA</i>
AFTR02	Trasmettitore allarmi tecnici <i>Technical alarms transmitter</i>	Gestisce n.2 ingressi filari tramite morsettiera a bordo del dispositivo per il controllo di due allarmi tecnici. Batteria: 1xCR123 inclusa. <i>It manages 2 wired input onboard through dedicated terminal on board for 2 technical alarms. Battery: 1xCR123 included.</i>
AFTRA03	Ripetitore segnali radio Dual-band <i>Dual-band signals radio repeater</i>	Ripete solo il segnale dei dispositivi ad esso associati (max 32) evitando in questo modo la saturazione della banda. Batteria: 1xCR123 inclusa. Numero massimo 4 per impianto. <i>Selective repeating of associated devices (max 32) avoiding band saturation. Battery: 1xCR123 included. Max n. 4 for plant.</i>
AF53900N	Sirena filare da esterno <i>Outdoor wired siren</i>	Possibilità di attivare la segnalazione sonora separata dalla segnalazione ottica. Tre differenti suoni selezionabili tramite ponticello. <i>Possibility of activating the sound signal separate from the optical signal. Three different sounds selectable by jumper.</i>
AF53903R-DB	Sirena radio da esterno Dual-band. <i>Dual band outdoor radio siren</i>	Batterie incluse. Segnalazione ottica ed acustica gestibili separatamente. Funzione di riproduzione allarme vocale. <i>Battery included. Optical and acoustic signalling manageable separately. Voice alarm play function.</i>



Per la disponibilità contattare la rete commerciale
For availability please contact sales dept.



Disponibilità fino ad esaurimento scorte
Available until stock out



Prodotto per scatola rettangolare inglese
Product for British standard rectangular box

Tabella per il dimensionamento delle centrali AF927PLUS - AF927PLUSTC
Sizing table for AF927PLUS - AF927PLUSTC central units

615

	Codice / Code	Descrizione / Description	Assorbimento / Consumption max.
CENTRALE CONTROL UNIT	AF927PLUS	Centrale radio/filo Radio/wired control unit	150 mA
	AF927PLUSTC	Centrale radio e filo con Touch screen a colori da 7" Radio/wired control unit with 7 inches touch screen	390 mA
MODULI INTERNI INTERNAL MODULES	AF927INTFIL	Interfaccia per bus filare Wired bus interface	20 mA
	AFGSM04-4G	Modulo GSM 4G 4G GSM module	80 mA - 300 mA
PERIFERICHE FILARI WIRED PERIPHERALS	AFEX6I-REN	Modulo remoto espansione a 6 ingressi Remote module expansion with 6 inputs	12 mA
	AF909RR	Scheda interfaccia BUS radio retrocompatibilità Bus radio interface card backwards compatibility	40 mA
	AF44..045	Inseritore tag da frutto S44 S44 transponder key reader	10 mA
	AF44..062	Rivelatore PIR filare da frutto S44 S44 wired PIR flush mounted detector	7 mA
	AF962	Rivelatore PIR via filo Wired PIR detector	7 mA
	AF963N	Rivelatore doppia tecnologia con antiaccecamento Dual technology detector with anti-blinding	30 mA
	AF969F	Rivelatore doppia tecnologia a tenda Dual technology curtain detector	32 mA
	AF973F	Rivelatore filare doppia tecnologia effetto tenda Wired dual technology curtain effect	27 mA
	AF974F	Rivelatore filare tripla tecnologia (2 PIR+MW) da esterno Outdoor triple technology (2 PIR+MW) wired detector	45 mA
	AFEXPU	Modulo uscita Output module	8 mA/25 mA
	AF990	Tastiera filare Wired keypad	350 mA con LCD acceso LCD ON
	SIRENA FILARE WIRED SIREN	AF53900N	Sirena filare da esterno Outdoor wired siren

Tabella per il dimensionamento delle centrali AF949PLUS o AF999PLUS
Sizing table for AF949PLUS or AF999PLUS central units



Dispositivo / Device	Descrizione / Description	Assorbimento / Consumption max.
AF999PLUS o AF949PLUS	Scheda madre centrale + tastiera touch screen (in stand by) Control unit and touch screen keyboard (stand by condition).	100 mA
AF999PLUS o AF949PLUS	Scheda madre centrale + tastiera touch screen (con retroilluminazione attiva) Control unit and touch screen keyboard (with backlight on)	140 mA
AF999PLUS o AF949PLUS	Scheda madre centrale + tastiera touch screen (con guida vocale attiva) Control unit and touch screen keyboard (with voice guidance on)	370 mA
AF984TS	Tastiera touch screen slave con retroilluminazione e lettore per tag transponder Backlighted slave touch screen keypad with electronic tag reader	350 mA con LCD acceso LCD ON
AFGSM03	Modulo GSM 2G (stand-by) - 2G GSM module (stand by condition)	30 mA
	Modulo GSM 2G (in trasmissione) - 2G GSM module (transmission condition)	350 mA
AFEX6I-REN	Modulo espansione remota a 6 ingressi - Remote expansion module with 6 inputs	12 mA
AF909RR	Modulo di espansione radio - Wireless expansion module	40 mA
AF44045	Inseritore transponder da incasso - Flush mounted transponder tag reader	10 mA
AFEXPU	Modulo uscita - Output module	8 mA/25 mA

Le dimensioni, salvo diversamente specificato, sono in mm
 Dimensions, except where otherwise specified, are in mm



Imballo Minimo pcs
Min. Packaging pcs

Imballo Standard pcs
Std. Packaging pcs



Antintrusione

Anti-intrusion

Centrali Radio/Filo
Wired/radio control unit



BREVETTO AVE n° 244
MODELLO COMUNITARIO
AVE PATENT n° 244 EU MODEL

616

Descrizione Description

Info

€ □ □



AF927PLUSTC

AF927PLUSTC

Centrale radio e filo dual band con web server e modulo Wi-Fi integrati. Alimentazione 230 Vac, alimentatore 1,6A. Gestione di massimo n.120 dispositivi (radio + filare su scheda interna + filare bus tramite AF927INTFIL) singolarmente identificabili tramite display LCD touch screen a colori da 7" e/o qualunque dispositivo dotato di web browser. In particolare:

- 99 canali radio diretti in centrale
- 8 ingressi filari a bordo centrale (16 con funzione double), resistenze di bilanciamento fornite a corredo.
- 120 ingressi filari tramite moduli remoti di espansione a 6 ingressi AFEX6I-REN
- 16 inseritori bus filare AF44..045

Possibilità di trasmettere messaggi vocali e/o SMS di allarme.

Sintesi vocale per registrazione segnalazioni vocali da abbinare ai messaggi segnalati sul display con modulo GSM/LTE.

Da completare con 2 batterie AF911.

Conforme a EN 50131-5-3, EN 50131-6, EN 50136-2, EN 50131-3 GR2/CLII.

Colore RAL 9016. Dimensioni: 270x262x82mm.

Dual band wireless and wired control unit with integrated web server and Wi-Fi module. 230 Vac power supply, 1.6A power supply. Management of up to 120 devices (radio + wired on internal board + wired bus via AF927INTFIL) individually identifiable by means of a 7" colour LCD touch screen display and / or any device equipped with a web browser. In particular:

- 99 radio channels directed to the control unit
- 8 wired inputs on central board (16 with double function), balancing resistors supplied.
- 120 wired inputs via AFEX6I-REN 6-input remote expansion modules
- 16 wire bus inserters AF44..045

Possibility of transmitting voice messages and / or alarm SMS.

Voice synthesis for recording voice signals to be combined with messages indicated on the display with GSM/LTE module.

To be completed with 2 AF911 batteries.

Standard compliance: EN 50131-5-3, EN 50131-6, EN 50136-2, EN 50131-3 GR2/CLII. Colour RAL 9016. Dimensions: 270x262x82mm.

1028,41 1 1



AF927PLUS

AF927PLUS

Centrale radio e filo dual band con web server e modulo Wi-Fi integrati. Alimentazione 230 Vac, alimentatore 1,6A. Gestione di massimo n.120 dispositivi (radio + filare su scheda interna + filare bus tramite AF927INTFIL) singolarmente identificabili tramite qualunque dispositivo dotato di web browser. In particolare:

- 99 canali radio diretti in centrale
- 8 ingressi filari a bordo centrale (16 con funzione double), resistenze di bilanciamento fornite a corredo.
- 120 ingressi filari tramite moduli remoti di espansione a 6 ingressi AFEX6I-REN
- 16 inseritori bus filare AF44..045

Possibilità di trasmettere messaggi vocali e/o SMS di allarme.

Sintesi vocale per registrazione messaggi audio con modulo GSM/LTE.

Da completare con 2 batterie AF911.

Colore RAL 9016. Dimensioni 270x262x82mm.

Dual band wireless and wired control unit with integrated web server and Wi-Fi module. 230 Vac power supply, 1.6A power supply. Management of up to 120 devices (radio + wired on internal board + wired bus via AF927INTFIL) individually identifiable through any device equipped with a web browser. In particular:

- 99 radio channels directed to the control unit
- 8 wired inputs on central board (16 with double function), balancing resistors supplied.
- 120 wired inputs via AFEX6I-REN 6-input remote expansion modules
- 16 wire bus inserters AF44..045

Possibility of transmitting voice messages and / or alarm SMS.

Voice synthesis for recording voice messages with GSM/LTE module.

To be completed with 2 AF911 batteries.

Colour RAL 9016. Dimensions 270x262x82mm.

820,47 1 1

Telecomandi e tastiere radio Wireless remote controls and keypads



Descrizione Description

Info

€ □ □



AF943R

per /for
AF927PLUS
AF927PLUSTC
AF949PLUS
AF999PLUS

AF943R

Telecomando a 4 pulsanti per sistema radio. Modalità di cambio codice di tipo "Rolling Code". Dialogo di tipo bidirezionale con le centrali della gamma radio. Indicazione di stato impianto a bordo tramite LED. Batteria: 1xCR2032 inclusa. Colore RAL 7035. Retrocompatibile con AF941R. Dimensioni: 11x84x32mm.

4-button remote control for radio system. Rolling Code code change mode. Two-way dialogue with the radio range control units. On-board system status indication via LED. Battery: 1xCR2032 included. Colour RAL 7035. Backwards compatible with AF941R. Dimensions: 11x84x32mm.

85,36 1 1



AF970R-DB

per /for
AF927PLUS
AF927PLUSTC

AF970R-DB

Tastiera multifunzione dual band per centrali radio. Dialogo di tipo bidirezionale. LCD retroilluminato per indicazione stato impianto/anomalie. Batteria 1xCR123 inclusa. Lettore per tag transponder AF340-T integrato. Dimensioni: 150x67x25mm.

Two-way dual band keypad for radio central units. Two-way dialogue with the radio range control units. Backlit LCD for indication of system status / anomalies. Battery 1xCR123 included. Integrated AF340-T with electronic tag reader. Dimensions: 150x67x25mm.

1 1



Per la disponibilità contattare la rete commerciale
For availability please contact sales dept.



Disponibilità fino ad esaurimento scorte
Available until stock out



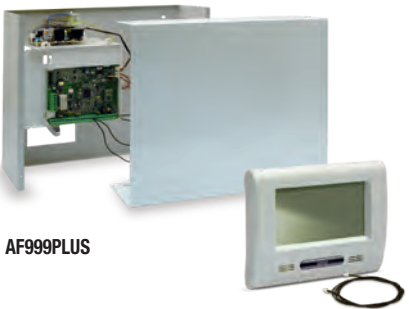
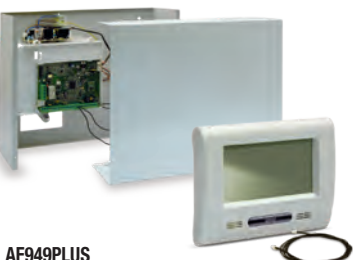

Prodotto per scatola rettangolare inglese
Product for British standard rectangular box

Centrali espandibili (Filo/Radio)
Expandable central units (Wired/Radio)

	Descrizione Description	Info	€		
 <p>AF999PLUS</p>	<p>AF999PLUS Kit composto da:</p> <ul style="list-style-type: none"> • AF999EXP Centrale antintrusione mista filo/radio, n.6 ingressi a bordo espandibili a n.128. La centrale dispone inoltre di combinatore telefonico PSTN e modulo di sintesi vocale. Centrale con alimentatore 4A. Possibilità di gestire fino a n.128 periferiche totali: - n.7 tastiere touch screen (n.1 master e n.6 slave) - n.2 moduli radio - n.16 moduli di uscita multifunzionali a relè - n.16 inseritori transponder. <p>Da completare con n.2 batterie AF919. Dimensioni: 380x365x130mm.</p> <ul style="list-style-type: none"> • AF984TM Tastiera touch screen master con retroilluminazione e lettore per tag transponder AF340-T integrato. E' dotata di una guida vocale che fornisce informazioni sia all'installatore che all'utente finale. Dimensioni: 106x135x30mm. <p>Kit with:</p> <ul style="list-style-type: none"> • AF999EXP wired/wireless anti-intrusion central unit with n.6 inputs onboard expandable to n.128. The central unit also has a PSTN telephone dialer and a voice synthesizer included. Central unit with 4A power supplier. It can control up to n.128 devices: - n.7 touch screen keyboards (n.1 master and n.6 slave) - n.2 radio modules - n.16 multifunctional relay output modules - n.16 transponder key readers. <p>To be completed with n.2 AF919 batteries. Dimensions: 380x365x130mm.</p> <ul style="list-style-type: none"> • AF984TM Backlighted master touch screen keyboard with electronic reader for tag AF340-T included. It has a voice guidance which gives information to the installer and to the user - Dimensions: 106x135x30mm. 		865,99	1	1
 <p>AF949PLUS</p>	<p>AF949PLUS Kit composto da:</p> <ul style="list-style-type: none"> • AF949 Centrale antintrusione mista filo/radio n.6 ingressi a bordo espandibili a n.36. La centrale dispone inoltre di combinatore telefonico PSTN e modulo di sintesi vocale. Centrale con alimentatore 1,5A. Possibilità di gestire fino a n.36 periferiche totali: - n.7 tastiere touch screen (n.1 master e n.6 slave) - n.2 moduli radio - n.16 moduli di uscita multifunzionali a relè - n.16 inseritori transponder. <p>Da completare con n.2 batterie AF912. Dimensioni: 340x255x80mm.</p> <ul style="list-style-type: none"> • AF984TM Tastiera touch screen master con retroilluminazione e lettore per tag transponder AF340-T integrato. E' dotata di una guida vocale che fornisce informazioni sia all'installatore che all'utente finale. Dimensioni: 106x135x30mm. <p>Kit with:</p> <ul style="list-style-type: none"> • AF949 wired/wireless anti-intrusion central unit with n.6 inputs onboard expandable to n.36. The central unit also has a PSTN telephone dialer and a voice synthesizer included. Central unit with 1,5A power supplier. It can control up to 36 devices: - n.7 touch screen keyboards (1 master and 6 slave) - n.2 radio modules - n.16 multifunctional relay output modules - n.16 transponder key readers. <p>To be completed with n.2 AF912 batteries. Dimensions: 340x255x80mm.</p> <ul style="list-style-type: none"> • AF984TM Backlighted master touch screen keyboard with electronic reader for tag AF340-T included. It has a voice guidance which gives information to the installer and to the user - Dimensions: 106x135x30mm. 		787,18	1	1

Tastiere filari Wired keypads



	Descrizione Description	Info	€		
 <p>AF984TS</p>	<p>AF984TS Tastiera touch screen slave con retroilluminazione e lettore per tag transponder AF340-T integrato. E' dotata di una guida vocale che fornisce informazioni sia all'installatore che all'utente finale. Per centrali AF999PLUS e AF949PLUS. Dimensioni: 106x135x30mm.</p> <p>Backlighted slave touch screen keypad with electronic reader for tag AF340-T included. It has a voice guidance which gives information to the installer and to the user. For AF999PLUS and AF949PLUS central units. Dimensions: 106x135x30mm.</p>		296,97	1	1
 <p>AF990</p>	<p>AF990 Tastiera filare touch screen per centrali della gamma AF927. Consente la gestione dell'inserimento/disinserimento/parzializzazione e la visualizzazione del registro eventi della centrale. È dotata di lettore transponder integrato per la gestione della centrale mediante TAG AF340-T. Colore bianco. È consentito un numero massimo di due tastiere associate alla centrale. Dimensioni (LxHxD): 106x135x30 mm.</p> <p>Wired touch screen keyboard for AF927 range control units. Allows management of arming/disarming/partitioning and viewing of the control panel event log. It is equipped with an integrated transponder reader for managing the control panel via TAG AF340-T. White color. A maximum number of two keypads associated with the control panel is allowed. Dimensions (LxHxD): 106x135x30 mm.</p>			1	1

DIVISIONE SICUREZZA
SAFETY-SECURITY

Le dimensioni, salvo diversamente specificato, sono in mm
Dimensions, except where otherwise specified, are in mm

 Prodotto per Export
For Export only

 Imballo Minimo pcs
Min. Packaging pcs

 Imballo Standard pcs
Std. Packaging pcs



Antintrusione









Anti-intrusion

Inseritori filari

Wired electronic key readers





618

Descrizione Description		Info	€	□	□
	AF340-T Chiave a transponder. Funziona con lettori AF441045, AF442045, AF443045 AF445045, AF449045 e centrali AF949PLUS, AF999PLUS, AF927PLUS, AF927PLUSTC. <i>Transponder Key. It works with AF441045, AF442045, AF443045 AF445045, AF449045 electronic readers and AF949PLUS, AF999PLUS, AF927PLUS, AF927PLUSTC central units.</i>		27,79	1	1
	AF441045 Inseritore transponder serie Domus. Consente di inserire (in modo totale o parziale) e disinserire le centrali AF999PLUS, AF949PLUS, AF927PLUS e AF927PLUSTC. Può essere utilizzato anche come controllo accessi. <i>Transponder key reader. Domus series. You can use it to arm (totally or partially) or disarm the central units AF999PLUS, AF949PLUS, AF927PLUS and AF927PLUSTC. It can be used also as access control.</i>		107,48	1	1
	AF442045 Come sopra serie Life. <i>As above Life series.</i>		116,93	1	1
	AF443045 Come sopra serie Allumia. <i>As above Allumia series.</i>		116,93	1	1
	AF445045 Come sopra serie Tekla. <i>As above Tekla series.</i>		107,48	1	1
	AF446045 Come sopra serie Whitek. <i>As above Whitek series.</i>		-	1	1
	AF449045 Come sopra serie Class. <i>As above Class series.</i>		107,48	1	1

per/for AF949PLUS - AF999PLUS - AF927PLUS - AF927PLUSTC



Moduli d'espansione Expansion modules

Descrizione Description		Info	€	□	□
	AFEX6I-REN Modulo remoto espansione a 6 ingressi per centrali AF999PLUS, AF949PLUS, AF927PLUS e AF927PLUSTC. Gli ingressi possono essere configurati liberamente (NC, singolo e doppio bilanciamento, conta impulsi). <i>Remote module expansion with 6 inputs for AF999PLUS, AF949PLUS, AF927PLUS and AF927PLUSTC central units. The inputs can be configured as single and double balanced, normally closed, pulse counting.</i>			1	1
	AFEXPU Modulo remoto di uscita con relè per centrali AF999PLUS, AF949PLUS, AF927PLUS e AF927PLUSTC. Funziona come monostabile temporizzato, "passo-passo" (ad es. per luci) o come "passo-passo con inversione" (ad es. per tapparelle). <i>Output module with relay for AF999PLUS, AF949PLUS, AF927PLUS and AF927PLUSTC central units. It can work as monostable timer relay, "step by step" (for ex. for light) or as step by step with inversion (for ex. for shutters).</i>			1	1
	AF909RR Modulo radio bidirezionale per centrali AF999PLUS, AF949PLUS, AF927PLUS e AF927PLUSTC. Permette di utilizzare tutti i dispositivi radio della gamma antintrusione radio. Installare massimo due moduli radio per ogni centrale. <i>Bidirectional wireless module for AF999PLUS, AF949PLUS, AF927PLUS and AF927PLUSTC central units. It allows you to use all the wireless security devices made by AVE. Please don't install more than two modules for each central unit.</i>			1	1

per/for AF949PLUS - AF999PLUS - AF927PLUS - AF927PLUSTC



Per la disponibilità contattare la rete commerciale
For availability please contact sales dept.







Disponibilità fino ad esaurimento scorte
Available until stock out



Prodotto per scatola rettangolare inglese
Product for British standard rectangular box







Interfacce e accessori filari
Wired interfaces and accessories

		Descrizione Description	Info	€	<input type="checkbox"/>	<input type="checkbox"/>
	per /for AF949PLUS - AF999PLUS	TSINT02 Interfaccia LAN per touch screen domotici. Permette di collegare le centrali AF999PLUS e AF949PLUS ai touch screen TS03B, TS03N, TS03B-V, TS03N-V, TS04, TS04V, TS05, TS01 e 53AB-WBS. <i>LAN interface for home automation touch screens. It allows to connect the AF999PLUS and AF949PLUS central units to the TS03B, TS03N, TS03B-V, TS03N-V, TS04, TS04V, TS05, TS01 touch screens and 53AB-WBS.</i>	1	1		
		AFPC02 Cavo per il collegamento delle centrali AF999PLUS e AF949PLUS ad un PC per effettuare, tramite il programma AVEBOX le operazioni di programmazione a livello locale. <i>Cable for connecting the AF999PLUS and AF949PLUS central units to a PC for local programming operations with the AVEBOX program.</i>	1	1		
	per /for AF927PLUS - AF927PLUSTC	AF927INTFIL Scheda d'interfaccia BUS filare per centrali AF927PLUS e AF927PLUSTC. Consente di collegare i moduli di espansione su bus filare. <i>Wired BUS interface card for control units AF927PLUS e AF927PLUSTC. It allows you to connect expansion modules on a wired bus.</i>	84,55	1	1	
		AF927INTLAN Interfaccia LAN per centrali AF927PLUS e AF927PLUSTC. Consente il collegamento delle centrali ad una rete LAN cablata. <i>Interface for LAN connection for control units AF927PLUS e AF927PLUSTC. It allows to connected the control units to a wired LAN.</i>	112,58	1	1	



Ricevitori, trasmettitori radio ed accessori Wireless receivers, transmitters and accessories

		Descrizione Description	Info	€	<input type="checkbox"/>	<input type="checkbox"/>
	per /for AF927PLUS - AF927PLUSTC AF949PLUS - AF999PLUS	AF909RR Modulo radio bidirezionale per centrali AF999EXP, AF949PLUS, AF927PLUS e AF927PLUSTC. Permette di utilizzare tutti i dispositivi radio della gamma antintrusione. Utilizzare massimo due moduli radio per ogni centrale. <i>Bidirectional radio module for AF999EXP, AF949PLUS, AF927PLUS and AF927PLUSTC central units. It allows you to use all the radio security devices made by AVE. Don't use more than two modules for each central unit.</i>	260,28	1	1	
		AFTRA02 Ripetitore di segnali radio dual band. Permette di aumentare la portata di trasmissione dei trasmettitori. Alimentazione: 230Vca. Completo di batteria ricaricabile (6V/1,2Ah). <i>Dual band radio signal repeater. It allows to increase the transmission range of the transmitter. Power supply 230Vac. Supplied with rechargeable battery (6V/1,2 Ah).</i>	372,92	1	1	
	per /for AF927PLUS - AF927PLUSTC	AFTRA03 Ripetitore di segnali radio dual band. Permette di aumentare la portata di trasmissione dei trasmettitori. Alimentazione: 230 Vca. Completo di batteria tampone (1XCR123). Colore RAL 9010. Max n.4 dispositivi per impianto. Dimensioni: 121x55x67mm. <i>Dual band radio signal repeater. It allows to increase the transmission range of the transmitters. Power supply: 230 V ac Comes with back-up battery (1XCR123). Colour RAL 9010. Max n.4 pcs for plant. Dimensions: 121x55x67mm.</i>	1	1		
		AFTR02 Interfaccia radio per allarmi tecnici. Trasmissione in doppia frequenza (Dual band). Segnale di allarme differenziato per i 2 ingressi ausiliari della morsetteria. Consente di interfacciare qualsiasi allarme tecnico dotato di uscita con contatto libero da potenziale. Batteria: 1xCR123 inclusa. Colore RAL 9016. Dimensioni: 23x25x134mm. <i>Radio interface for technical alarms. Dual frequency transmission (Dual Band). Differentiated alarm signal for the 2 auxiliary inputs of the terminal board. It allows interfacing of any technical alarm with potential-free contact output. Battery: 1xCR123 included. Colour RAL 9016. Dimensions: 23x25x134mm</i>	1	1		

DIVISIONE SICUREZZA
SAFETY-SECURITY

Le dimensioni, salvo diversamente specificato, sono in mm
Dimensions, except where otherwise specified, are in mm

Prodotto per Export
For Export only

Imballo Minimo pcs
Min. Packaging pcs

Imballo Standard pcs
Std. Packaging pcs

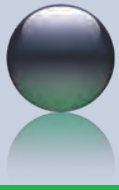

Antintrusione

Anti-intrusion

Diagrammi di copertura

Coverage diagram

620

Caratteristiche Tecniche Technical Features

AF44x062

Vista dall'alto - Top view

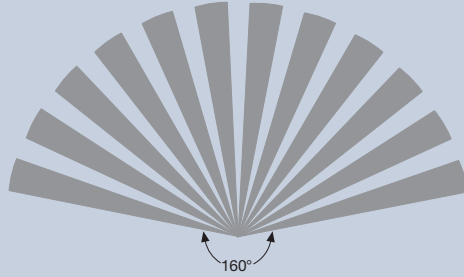

Vista laterale - Side view

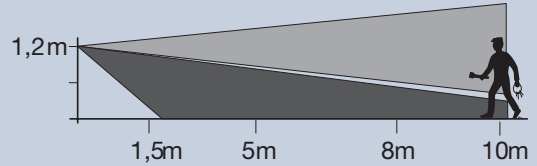

AF962

Vista dall'alto - Top view

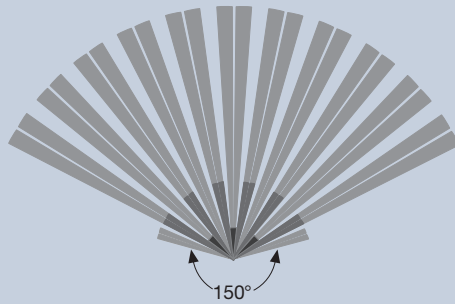

Vista laterale - Side view

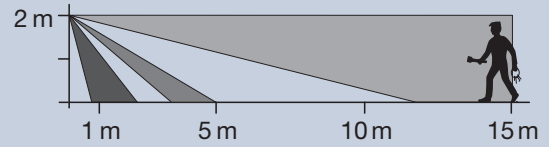

AF963N

Vista dall'alto - Top view

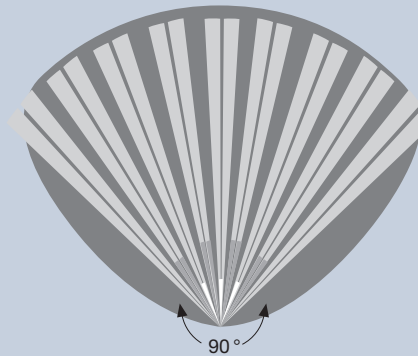

Vista laterale - Side view

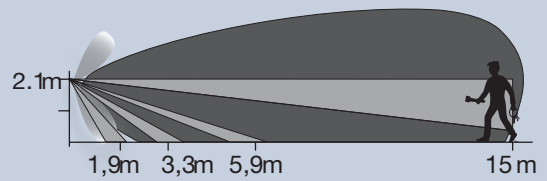

AF963R-DB

Vista dall'alto - Top view

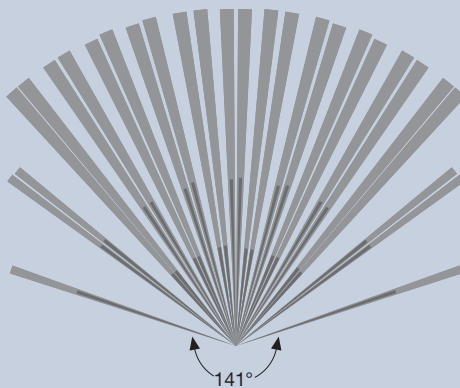

Vista laterale - Side view

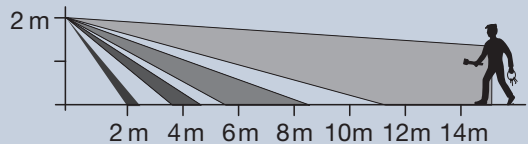

Per la disponibilità contattare la rete commerciale
For availability please contact sales dept.











Disponibilità fino ad esaurimento scorte
Available until stock out



Prodotto per scatola rettangolare inglese
Product for British standard rectangular box





Rivelatori filari da incasso Wired flush mounted detectors

			Descrizione Description	Info	€	<input type="checkbox"/>	<input type="checkbox"/>
			AF441062 Rivelatore PIR via filo da incasso. Assorbimento 7mA. Portata 10m. Contatto d'uscita libero da potenziale - serie Domus <i>Wired PIR flush mounted detector. 7mA current consumption. Range 10m. Dry contact - Domus series.</i>		123,85	1	1
AF441062	AF442062	AF443062	AF442062 Come sopra - serie Life. <i>See above - Life series.</i>		127,35	1	1
			AF443062 Come sopra - serie Allumia. <i>See above - Allumia series.</i>		127,35	1	1
			AF445062 Come sopra - serie Tekla. <i>See above - Tekla series.</i>		123,85	1	1
AF445062	AF461062	AF449062	AF446062 Come sopra - serie Whitek. <i>See above - Whitek series.</i>	 	-	1	1
			AF449062 Come sopra - serie Class. <i>See above - Class series.</i>		123,85	1	1

Nota: prevedere un contatto ausiliario per la protezione antirimozione del dispositivo.
Note: please provide an auxiliary contact to ensure the tamper protection of the device.





Rivelatori filari volumetrici da parete Wired volumetric wall mounted detectors

			Descrizione Description	Info	€	<input type="checkbox"/>	<input type="checkbox"/>
			AF962 Rivelatore PIR via filo. Portata 15m. Assorbimento 7mA. <i>Wired PIR detector. 15m range. 7mA current consumption.</i>		52,18	1	1
AF961	AF962		AF961 Snodo per rivelatori a parete. Per AF962, AF968R-DB e AF974R-DB. <i>Adjustable joint for detectors. For AF962, AF968R-DB and AF974R-DB.</i>		7,61	1	10
			AF963N Rivelatore doppia tecnologia con antiaccecamento. Assorbimento 30mA. Fornito con snodo. <i>Dual technology detector with anti-blinding. 30mA current consumption. Joint included.</i>		87,85	1	1



Rivelatori radio volumetrici da parete Wireless volumetric wall mounted detectors

			Descrizione Description	Info	€	<input type="checkbox"/>	<input type="checkbox"/>
			AF968R-DBN Rivelatore volumetrico di movimento PIR (passive infra-red detector), Trasmissione in doppia frequenza 433 - 868 MHz. <i>Volumetric PIR movement detector (passive infra-red detector), 433 - 868 MHz dual frequency transmission.</i>			1	1
AF968R-DBN			AF963R-DB Rivelatore PIR via radio. Trasmissione in doppia frequenza, Dual Band. Batteria: 1xCR123 inclusa. Colore RAL 9016. Dimensioni: 68x51x112mm. <i>Radio PIR detector. Dual frequency transmission, Dual Band. Battery: 1xCR123 included. Colour RAL 9016. Dimensions: 68x51x112mm</i>		140,40	1	1
			AF961N Snodo angolare per rivelatore AF963R-DB. Dimensioni: 68x51x112mm. <i>Angular joint for detector AF963R-DB. Dimensions: 68x51x112mm</i>		5,63	1	1

Le dimensioni, salvo diversamente specificato, sono in mm
Dimensions, except where otherwise specified, are in mm

 Prodotto per Export
For Export only

Imballo Minimo pcs
Min. Packaging pcs

Imballo Standard pcs
Std. Packaging pcs

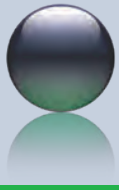

Antintrusione

Anti-intrusion

Diagrammi di copertura

Coverage diagram

622

AF973F

Vista laterale - Side view

Protezioni di varchi e vetrate
Passages and windows protections

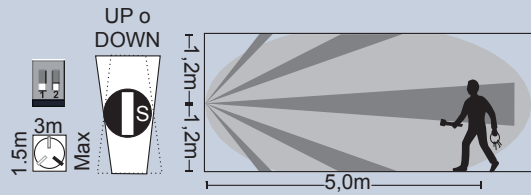
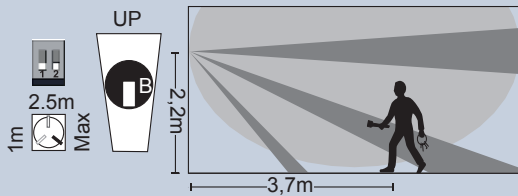
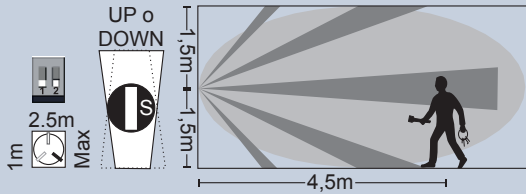

Vista dall'alto - Top view

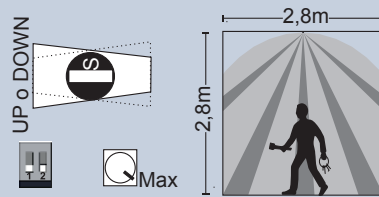
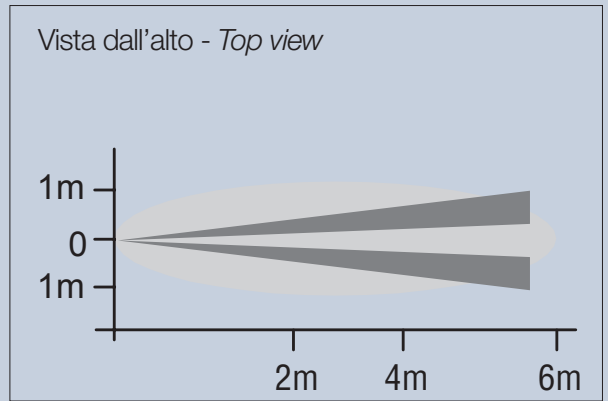

Protezioni di varchi e vetrate con Pet Immunity
Passages and windows protections with Pet Immunity

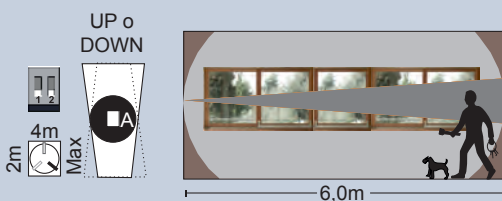
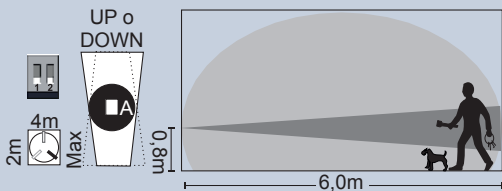
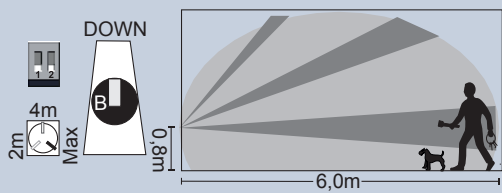

Protezioni di finestre e tapparelle
Shutters and windows protections

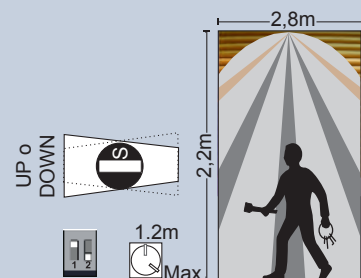
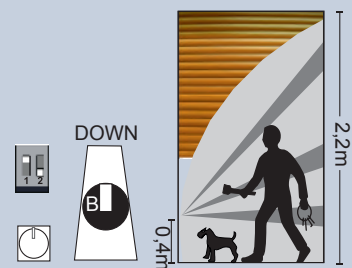

Caratteristiche Tecniche Technical Features



Per la disponibilità contattare la rete commerciale
For availability please contact sales dept.



Disponibilità fino ad esaurimento scorte
Available until stock out



Prodotto per scatola rettangolare inglese
Product for British standard rectangular box











Rivelatori filari ad effetto tenda

Wired curtain effect detectors

		Descrizione Description	Info	€	□	□
	AF973F	AF973F Rivelatore doppia tecnologia a tenda per la protezione di varchi. Portata massima: 6m. Assorbimento 27mA. Conforme alla norma EN 50131-2-4 Grado 2. Classe ambientale III (esterno riparato). Dimensioni: 87x32x35mm. <i>Dual technology curtain effect detector for the protection of openings. Maximum range: 6m. Current consumption 27mA. Standard compliance: EN50131-2-4 Grade 2, CLASS III (Outdoor - Sheltered or indoor extreme conditions). Dimensions: 87x32x35mm.</i>		116,89	1	1

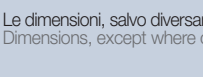

Rivelatori filari perimetrali Wired perimeter detectors

		Descrizione Description	Info	€	□	□
	AF902	AF902 Contatto magnetico via filo a sigaretta. <i>Wired flushed magnetic contact.</i>		7,43	10	10
	AF903	AF903 Contatto magnetico via filo da superficie. <i>Wired surface magnetic contact.</i>		7,97	10	10
	AF930	AF930 Contatto magnetico via filo in ottone da incasso per porte blindate. <i>Wired flush mounted brass magnetic contact for security doors.</i>		21,03	1	1
	AF931	AF931 Contatto magnetico via filo di potenza in alluminio, da superficie per infissi in metallo. <i>Wired aluminium wall mounted magnetic contact for metal surfaces.</i>		31,92	1	2
	AF933	AF933 Contatto magnetico via filo in alluminio per porte basculanti. <i>Wired aluminium magnetic contact for access ways.</i>		38,84	1	1
	AF931	AF931 Rivelatore movimento tapparelle via filo. Utilizzare con rivelatore AF914R-DB o con AFIP1. <i>Wired roll-up shutters detector. To be used with AF914R-DB or AFIP1.</i>		17,01	1	1
	AF933	AF933 Scheda contaimpulsi per AF931. Utilizzabile per il collegamento del rivelatore AF931 all'ingresso di centrali via filo. Alimentazione 12Vcc. <i>Impulse counter board for AF931. It can be used to connect the AF931 detector to the control unit. Power supply 12Vdc.</i>		61,25	1	1
	AFIN1	AFIN1 Rivelatore inerziale di vibrazione in materiale termoplastico. Adatto alla protezione di porte, finestre, vetrate o dovunque si voglia rilevare un urto. Deve essere interfacciato alla scheda contaimpulsi AFIP2 che permette di regolarne la sensibilità. <i>Thermoplastic inertial vibration detector. It is suitable for the protection of doors, windows, glasses and wherever it is requested to detect an impact. To be connected to the pulse counter board AFIP2 in order to adjust sensitivity.</i>		32,90	1	5
	AFRTP1	AFRTP1 Scheda contaimpulsi per AFIN1. Utilizzabile per il collegamento del rivelatore AFIN1 all'ingresso di centrali via filo. <i>Pulse counter board for AFIN1. It can be used to connect the AFIN1 detector to the central units.</i>		64,47	1	1
	AFIP2					
	AFIP1					



Antintrusione

Anti-intrusion

Diagrammi di copertura

Coverage diagram

624

Caratteristiche Tecniche Technical Features

AF969F

Vista laterale - Side view

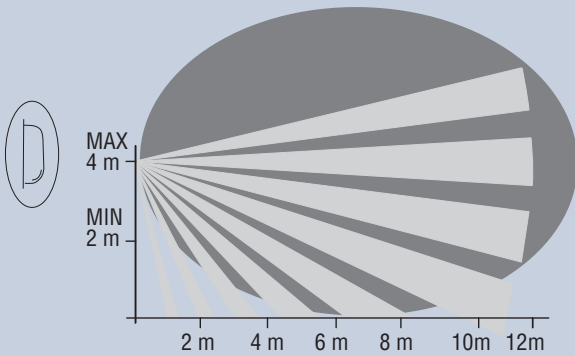

Vista dall'alto - Top view

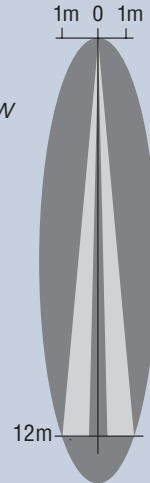

Vista laterale con parzializzatore lente - Side view with blinding lens

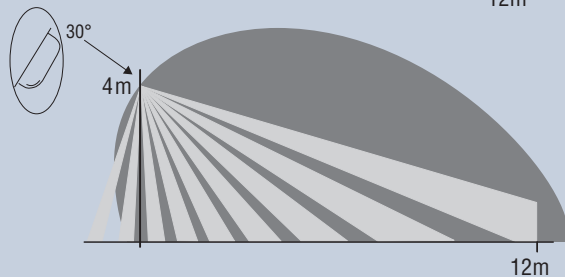
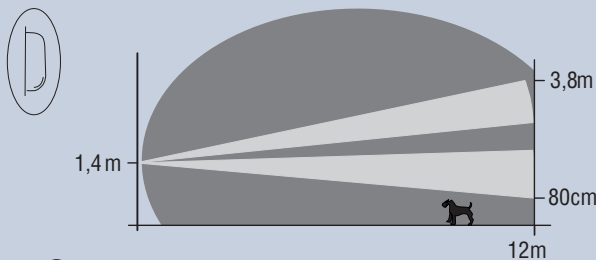

Nota: Prediligere installazioni dove ci sia un muro / pavimento a delimitare il campo di rilevazione del sensore. Se il sensore è puntato nel vuoto la distanza di copertura si riduce a 8m. Dove non sia possibile una installazione parete/parete o soffitto/pavimento prediligere l'installazione a sensore inclinato.

Note: Please prefer installations where there is a wall / floor to delimit the field of detection of the sensor. If the sensor is pointed in a vacuum space the coverage distance is reduced to 8m. Where is not possible a wall / wall or ceiling / floor installation, it is preferred a tilted sensor installation.

AF974F

Vista laterale - Side view

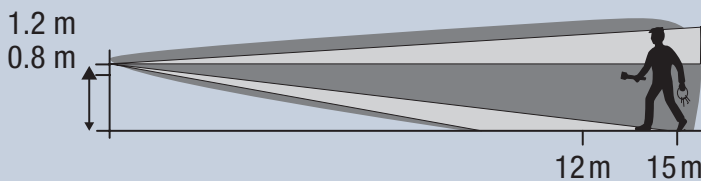

Vista dall'alto - Top view

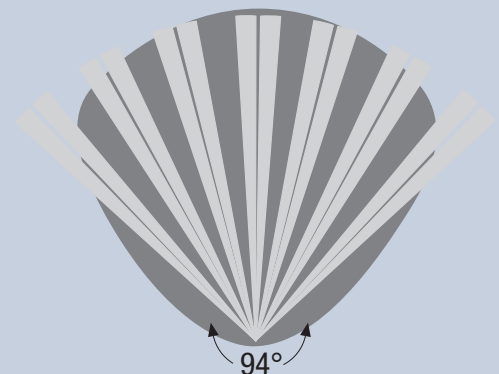

Per la disponibilità contattare la rete commerciale
For availability please contact sales dept.







Disponibilità fino ad esaurimento scorte
Available until stock out



Prodotto per scatola rettangolare inglese
Product for British standard rectangular box







Rivelatori radio perimetrali Wireless perimeter detectors

Descrizione Description		Info	€	<input type="checkbox"/>	<input type="checkbox"/>
		per /for AF949PLUS - AF999PLUS	AF914R-DB Rivelatore perimetrale via radio, colore bianco, per centrali AF949PLUS, AF999PLUS e AF926PLUS. Trasmissione in doppia frequenza (Dual band). Segnale di allarme differenziato per contatto magnetico e ingresso ausiliario della morsettiere. Dimensioni: 136x31x28mm. <i>Wireless perimeter detector, white colour, for AF949PLUS, AF999PLUS and AF926PLUS central units. Dual band transmission. Different alarm signals for magnetic contact and auxiliary onboard input. Dimensions: 136x31x28mm.</i>	1	1
			AF914R-MDB Come sopra - colore marrone. <i>See above - brown colour.</i>	1	1
		per /for AF927PLUS - AF927PLUSTC	AF915R-DB Rivelatore perimetrale via radio, colore bianco RAL 9016, per centrali AF927PLUS e AF927PLUSTC. Trasmissione in doppia frequenza (Dual band). Segnale di allarme differenziato per contatto magnetico e n.2 ingressi ausiliari della morsettiere. Doppio reed di cui uno per funzione tamper magnetico. Batteria: 1xCR123 inclusa. Dimensioni: 23x25x134mm. <i>Radio perimeter detector, white RAL 9016 colour, for AF927PLUS and AF927PLUSTC central units. Dual frequency transmission (Dual Band). Differentiated alarm signal for magnetic contact and n.2 auxiliary inputs of the terminal board. Double reed, one of which for magnetic tamper function. Battery: 1xCR123 included. Dimensions: 23x25x134mm.</i>	87,26	1 1
			AF915R-MDB Come sopra - colore marrone. <i>See above - brown colour.</i>	87,26	1 1



Rivelatori filari da esterno Wired outdoor detectors

Descrizione Description		Info	€	<input type="checkbox"/>	<input type="checkbox"/>
		AF969F Rivelatore doppia tecnologia a tenda per la protezione di varchi. Portata massima: 12m. Assorbimento 32mA. Conforme alla norma EN 50131-2-4 Grado 2. Classe ambientale IV (esterno). Dimensioni: 110x44x46 mm. Fornito con tettuccio, staffa per montaggio angolare (90°) e lente PET immunity. <i>Dual technology curtain detector for the protection of openings. Maximum range: 12m. Current consumption 32mA. Standard compliance: EN50131-2-4 Grade 2, CLASS IV (Outdoor). Dimensions: 110x44x46 mm. Protection cover, angle bracket and PET immunity lens included.</i>	238,93	1	1
			AF969S Snodo per AF969F. <i>Joint for AF969F.</i>	22,13	1
		AF974F Rivelatore volumetrico di movimento a triplo sensore: doppio PIR (passive infra-red detector che rileva elementi di temperatura differente rispetto allo sfondo generando un allarme) e microonda (che analizza le radiazioni riflesse di un corpo in movimento). Portata massima: 12m. Assorbimento 45mA. Conforme alla norma EN 50131-2-4 CLASSE III GRADO 2. Dimensioni: 185X85X80 mm. Fornito con tettuccio. <i>Triple-sensor volumetric motion detector: double PIR (passive infra-red detector that detects elements of different temperature than the background, generating an alarm) and microwave (which analyzes the reflected radiation of a moving body). Maximum range: 12m. Current consumption 45mA. Standard compliance: EN 50131-2-4 CLASSE III GRADO 2. Dimensions: 185X85X80 mm. Protection cover included.</i>	252,76	1	1
			AF974S Snodo per AF974F. <i>Joint for AF974F.</i>	20,26	1

DIVISIONE SICUREZZA
SAFETY-SECURITY

Le dimensioni, salvo diversamente specificato, sono in mm
Dimensions, except where otherwise specified, are in mm

Prodotto per Export
For Export only

Imballo Minimo pcs
Min. Packaging pcs

Imballo Standard pcs
Std. Packaging pcs



Antintrusione

Anti-intrusion

Diagrammi di copertura

Coverage diagram

626

AF965R-DB - AF975R-DB

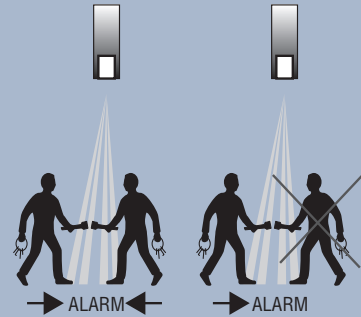
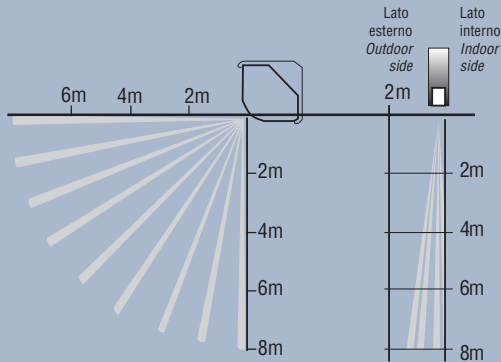

Nota: L'allarme avviene attraversando entrambe le barriere create dai sensori PIR, oppure prima quella esterna, poi quella interna (non il contrario).
 Consente la gestione in AND o OR delle barriere create dai sensori PIR
 Note: The alarm is sent only if you go through both the two curtains created by the 2 PIR or if you go through the external curtain and then through the internal one (it doesn't work in the reverse way).
 Allows AND or OR management of the two curtains created by the PIR sensors.

AF965R-DB

Da utilizzare solo con centrali
 AF927PLUS - AF927PLUSTC
 To be used only with control unit
 AF927PLUS - AF927PLUSTC

AF975R-DB

Da utilizzare solo con centrali
 AF949PLUS - AF999PLUS - AF926PLUS
 To be used only with control unit
 AF949PLUS - AF999PLUS - AF926PLUS

AF964R-DB

Vista verticale Vertical view

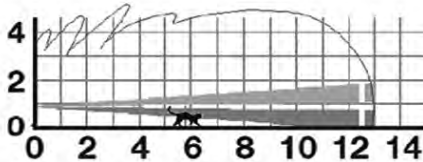

Vista in pianta Plan view

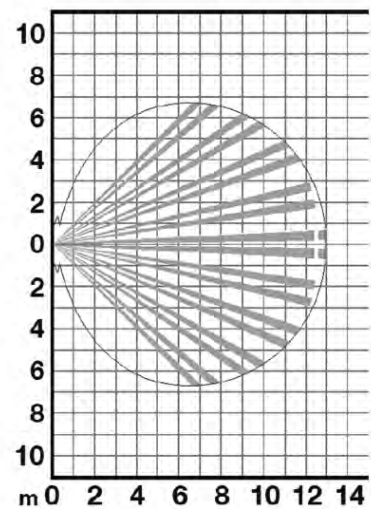

Caratteristiche Tecniche Technical Features



Per la disponibilità contattare
 la rete commerciale
 For availability please contact
 sales dept.



Disponibilità fino ad
 esaurimento scorte
 Available until stock out



Prodotto per scatola
 rettangolare inglese
 Product for British standard
 rectangular box

AF974R-DB

Diagramma sensore PIR – Vista dall'alto
 PIR sensor coverage – Top view



Diagramma sensore PIR – Vista laterale
 PIR sensor coverage – Side view



Diagramma sensore MW – Vista dall'alto
 MW sensor coverage – Top view

AF976R-DB

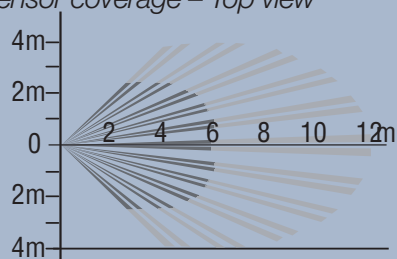
Vista in pianta *Plan view*

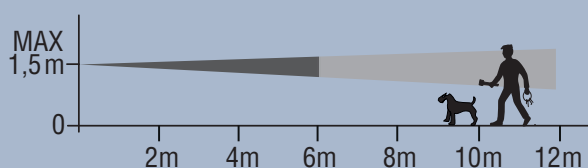
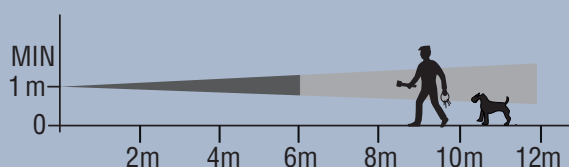
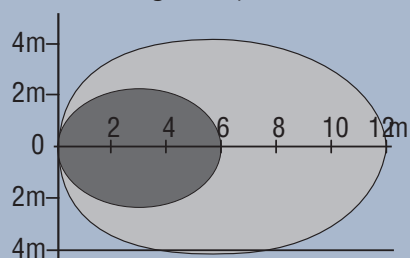
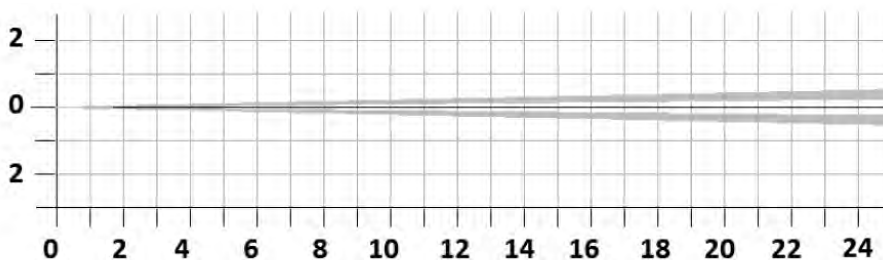

Vista verticale *Vertical view*

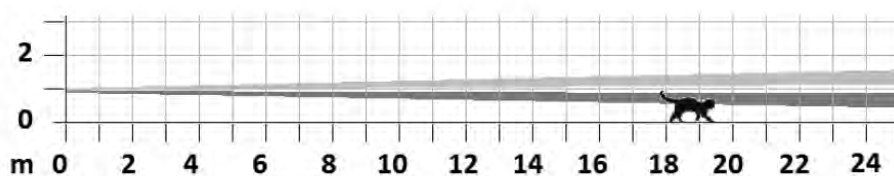



Antintrusione

Anti-intrusion

Rivelatori radio da esterno e/o esterno riparato
Wireless outdoor and/or sheltered outdoor detectors



628

Descrizione Description

Info

€

□

□



AF974R-DBS

AF974R-DB

AF974R-DB 387,20 1 1

Rivelatore doppia tecnologia radio per esterno riparato. Trasmissione dual band. Compatibile con le centrali radio AVE (AF926PLUS, AF949PLUS e AF999PLUS). Da completare con snodo AF961. Alimentazione: n.3 batterie AA 1,5V. Dimensioni: 155x87x48mm.
Dual technology radio detector for sheltered outdoor use. Dual band transmission. It can be used with the radio central units made by AVE (AF926PLUS, AF949PLUS and AF999PLUS). To be completed with AF961 joint. Power supply: n.3 1,5V AA batteries. Dimensions: 155x87x48mm.

per / for
AF949PLUS - AF999PLUS

AF974R-DBS 69,68 1 1

Snodo e cover per AF974R-DB. Permette la corretta protezione del rivelatore AF974R-DB.
Joint and cover for AF974R-DB. It allows the correct protection of the AF974R-DB detector.



AF975R-DB

AF975R-DB 218,15 1 1

Rivelatore perimetrale radio dual band a doppio sensore PIR e antiaccecamento. L'allarme avviene attraversando entrambe le barriere create dai PIR, oppure prima quella esterna, poi quella interna (non il contrario): le due possibilità sono selezionabili in funzione dell'utilizzo. Portata 8m. Classe ambientale III (esterno riparato). Batteria CR123. Dimensioni: 80x80x23mm.
Da utilizzare solo con centrali AF949PLUS - AF999PLUS - AF926PLUS
Dual band radio curtain effect detector with double PIR and anti-blinding functional. The alarm is sent only if you go through both the two curtains created by the 2 PIR or if you go through the external curtain and then through the internal one (it doesn't work in the reverse way). The installer can select the two different functions. Range 8m. ENVIRONMENTAL CLASS III (Sheltered outdoor or indoor extreme conditions). Battery CR123. Dimensions: 80x80x23mm.
To be used only with control unit AF949PLUS - AF999PLUS - AF926PLUS



AF964R-DBS

AF964R-DB

AF964R-DB 1 1

Rivelatore da esterno volumetrico di movimento a doppio PIR + microonde, funzione pet immunity. Fornito con staffa di supporto a muro. Il magnete anti asportazione fornito in dotazione deve essere sempre montato. Installazione "a bandiera" mediante lo snodo AF964R-DBS.
Dual PIR and microwave volumetric motion detector for outdoor use, pet immunity function available. Supplied with wall support bracket. The supplied magnet must always be fitted. "Flag" installation using the AF964R-DBS joint.

AF964R-DBS 1 1

Snodo per AF964R-DB e AF976R-DB
Joint for AF964R-DB and e AF976R-DB



AF965R-DB

per / for
AF927PLUS - AF927PLUSTC

AF965R-DB 1 1

Rivelatore perimetrale radio dual band a doppio sensore PIR e antiaccecamento. L'allarme avviene attraversando entrambe le barriere create dai PIR, oppure prima quella esterna, poi quella interna (non il contrario): le due possibilità sono selezionabili in funzione dell'utilizzo. Consente la gestione in AND o OR delle barriere create dai sensori PIR. Portata 8 m. Classe ambientale III (esterno riparato). Batteria: 1xCR123 inclusa. Colore RAL 9016. Dimensioni: 79x23x79mm.
Da utilizzare solo con centrali AF927PLUS - AF927PLUSTC
Dual band radio perimeter detector with dual sensor PIR and anti-blinding. The alarm is triggered by crossing both barriers created by the PIR sensors, or first the outdoor one, then the indoor one (not the opposite): the two options can be selected according to use. Allows AND or OR management of the two curtains created by the PIR sensors. Range 8 m. Environmental class III (outdoor sheltered). Battery: 1xCR123 included. Colour RAL 9016. Dimensions: 79x23x79mm.
To be used only with control unit AF927PLUS - AF927PLUSTC

AF976R-DB 1 1

Rivelatore effetto tenda da esterno, doppio PIR. Batterie: 2xCR123. Portata 25m. Fornito con staffa di supporto a muro. Il magnete anti asportazione fornito in dotazione deve essere sempre montato. Installazione "a bandiera" mediante lo snodo AF964R-DBS.
Dual infra-red detectors. Two passive PIR infrared sensors. 2xCR123 batteries. Range 25m. The supplied magnet must always be fitted. "Flag" installation using the AF964R-DBS joint.



AF964R-DBS

AF976R-DB



Per la disponibilità contattare la rete commerciale
For availability please contact sales dept.





Disponibilità fino ad esaurimento scorte
Available until stock out



Prodotto per scatola rettangolare inglese
Product for British standard rectangular box

Combinatori telefonici Telephone diallers

	Descrizione <i>Description</i>	Info	€	□	□	629
 AF986GSM	AF986GSM Combinatore telefonico via filo bidirezionale GSM 2G: n.4 canali vocali, n.4 canali SMS, n.6 SMS tecnici, n.2 uscite open collector comandabili anche da SMS. Tastiera alfanumerica e display LCD a bordo. Da completare con n.2 batterie AF916. Alimentazione 10-14Vcc. Dimensioni: 161x110x30mm. <i>Hardwired 2-way 2G GSM telephone dialler. n.4 channels with vocal messages, n.4 channels with SMS, n.6 technical SMS, n.2 open collector outputs that you can manage also via SMS. Alphanumeric keyboard and LCD on board. To be completed with n.2 AF916 batteries. Power Supply: 10-14Vdc. Dimensions: 161x110x30mm.</i>		321,40	1	1	
 AFGSM03	AFGSM03 Modulo GSM per combinatore telefonico. Collegato alla scheda madre delle centrali AF999EXP e AF949PLUS, permette la trasmissione degli allarmi delle centrali AF999EXP e AF949PLUS sulla linea GSM 2G. Permette il controllo completo della centrale anche tramite SMS. <i>GSM module for telephone dialler. Connected to the main board of the AF999EXP and AF949PLUS central units it allows to transmit via the GSM 2G network the alarms coming from the AF999EXP and AF949PLUS central units. It allows the complete control of the central unit also via SMS.</i>	per /for AF999PLUS - AF949PLUS			1	1
 AFGSM04-4G	AFGSM04-4G Modulo GSM 4G-LTE. Consente la gestione completa delle centrali da remoto, l'invio di messaggi SMS e le chiamate vocali. <i>4G-LTE GSM module. It allows the complete management of the control panels remotely, the sending of SMS messages and voice calls.</i>	per /for AF927PLUS - AF927PLUS1C	273,83	1	1	



Nota: disponibili moduli GSM con antenna esterna. Per la disponibilità contattare la rete commerciale
 Note: GSM module available with external antenna. For availability please contact sales dept.

AF964R-DBS Montaggio Mounting

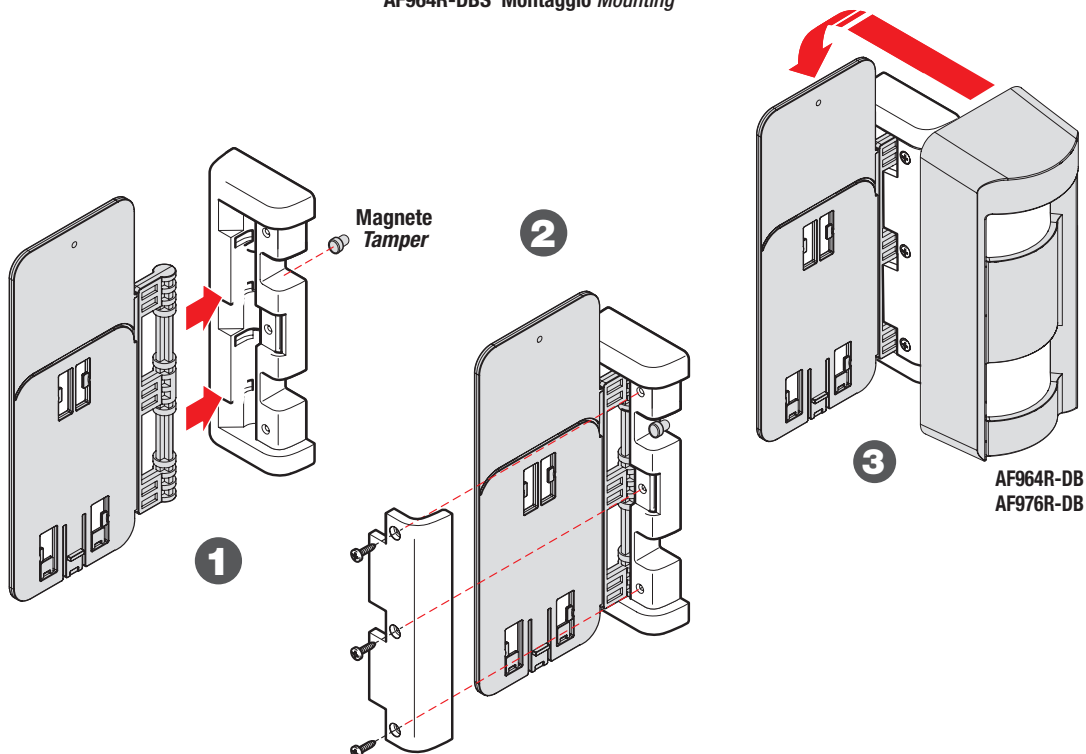



Antintrusione

Anti-intrusion

Sirene filari
Wired sounders



630



AF53900N
AF53900VN
Design: Luca Merletti



AF999RS



AF442099RS

Descrizione Description

Info

€ □ □

AF53900N
Sirena autoalimentata da esterno. Pressione acustica 123dB a 1m. IP34.
Da completare con n.1 batteria AF911.
*Outdoor self powered siren. 123dB at 1m acoustic pressure. IP34.
To be completed with n.1 AF911 battery.*

139,32 1 1

AF53900VN
Sirena senza componenti interni per l'utilizzo come deterrente.
Sounder without internal components to be used as a deterrent.

53,37 1 1

AF999RS
Sirena ausiliaria filare da parete. Pressione acustica 90dB a 3m
Alimentazione 12Vcc - 120mA.
*Wired wall mounted auxiliary siren. 90dB at 3m acoustic pressure.
Power supply: 12Vdc - 120mA .*

79,21 1 1

AF442099RS
Sirena ausiliaria rossa da incasso. Utilizzabile anche come avvisatore acustico grazie alla possibilità di impostazione di due livelli di intensità sonora. Possibilità di scelta di 4 diversi suoni acustici. Pressione acustica 90dB a 3m. Alimentazione 12Vcc. S44.
Flush-mounted auxiliary red siren. It can also be used as an acoustic alarm thanks to the possibility of two sound intensity levels. Possibility to choose among 4 different acoustic sounds. Sound pressure 90dB at 3m. 12Vdc power supply. S44.

78,96 1 1



Design: Luca Merletti

Sirene radio Wireless sounders

Descrizione Description

Info

€ □ □



AF53902R-DB



AF53903R-DB

per /for
AF999PLUS
AF949PLUS

AF53902R-DB
Sirena radio dual band con messaggi vocali. Batteria AF915 inclusa.
Compatibile con le centrali radio AVE AF926PLUS, AF949PLUS e AF999PLUS.
*Dual band wireless siren with vocal messages. AF915 battery included.
It can be used with the radio central units made by AVE AF926PLUS, AF949PLUS
and AF999PLUS.*

1 1

per /for
AF927PLUS - AF927PLUSTC

AF53903R-DB
Sirena radio dual band con messaggi vocali. Possibilità di selezionare la segnalazione ottica e/o acustica in modo indipendente per i vari eventi.
Compatibile con le centrali radio AVE (AF927PLUS e AF927PLUSTC).
Elevato grado di autoestinguenza secondo Normativa 50131-4.
Batteria: AF53903R-BAT inclusa. Colore RAL 9016. Dimensioni: 350x100x240mm.
*Dual band radio siren with voice messages. Optical and acoustic signals can be independently selected for each type of event. It can be used with the radio central units made by AVE (AF927PLUS and AF927PLUSTC).
High degree of self-extinguishing according to 50131-4 Standard.
Battery: AF53903R-BAT included. Colour RAL 9016. Dimensions: 350x100x240mm.*

299,92 1 1



Per la disponibilità contattare la rete commerciale
For availability please contact sales dept.



Disponibilità fino ad esaurimento scorte
Available until stock out



Prodotto per scatola rettangolare inglese
Product for British standard rectangular box



Alimentatori - Trasformatori - Batterie Power supplies - Transformers - Batteries

	Descrizione <i>Description</i>	Info	€	□	□
	ALI12-5A Alimentatore ausiliario con n.2 uscite (presenza alimentazione, tensione batteria bassa). Da completare con n.2 batterie AF912 <i>Auxiliary power supply with 2 outputs (power supply, low battery voltage). To be completed with n.2 AF912 batteries.</i>		246,30	1	1
	441082ALI Alimentatore supplementare da incasso n.1 modulo S44 - serie Domus. Tensione di ingresso: 90-255Vca - 50-60Hz. Tensione d'uscita 12Vcc. Corrente erogabile: 400mA a servizio continuo. <i>Additional flush mounted power supply n.1 module S44 - Domus series. Input voltage 90-255Vac - 50-60Hz. Output voltage 12Vdc. Suppliable current: 400mA continuous.</i>		76,75	1	1
ALI 12-5A	443082ALI Come sopra. S44 serie Allumia. <i>See above. S44 Allumia series.</i>		82,63	1	1
	445082ALI Come sopra. S44 serie Tekla. <i>See above. S44 Tekla series.</i>		76,75	1	1
	449082ALI Come sopra. S44 serie Class (RAL 1013). <i>See above. S44 Class series (RAL 1013).</i>		76,75	1	1
	45382G Trasformatore 230/12V 2VA. Serie Noir. <i>Transformer 230/12V 2VA. Noir series.</i>		58,36	1	6
	45B82G Trasformatore 230/12V 2VA. Serie Banquise. <i>Transformer 230/12V 2VA. Banquise series.</i>		56,78	1	6
441082ALI	5347 Trasformatore 230/12-24V 15VA. 2 mod DIN. <i>Transformer 230/12-24V 15VA. 2 DIN modules.</i>		44,39	1	1
443082ALI	AF53903R-BAT Batteria di ricambio per sirena radio AF53903R-DB <i>Replacement battery for AF53903R-DB radio siren</i>		51,38	1	1
445082ALI	AF911 Batteria ricaricabile 12V 1,8 Ah (per AF53900, AF53900N, AF926, AF926PLUS, AF927PLUS e AF927PLUSTC). <i>Rechargeable battery 12V 1,8 Ah (for AF53900, AF53900N, AF926, AF926PLUS, AF927PLUS and AF927PLUSTC).</i>		40,84	1	1
449082ALI	AF912 Batteria ricaricabile 12V 6,5 Ah (per AF997, AF998EXP, AF949PLUS e AF999PLUS). <i>Rechargeable battery 12V 6,5Ah (for AF997, AF998EXP, AF949PLUS and AF999PLUS).</i>		52,24	1	1
	AF915 Batteria al litio 7,2V 13Ah (per AF53901R-DB e AF53902R-DB). <i>Lithium battery 7,2V 13Ah (for AF53901R-DB and AF53902R-DB).</i>		140,49	1	1
45382G	AF916 Batteria al litio 3,6V 2,2Ah (per AF906RR) e AF986GSM. <i>Lithium battery 3,6V 2,2Ah (for AF906RR) and AF986GSM.</i>		27,44	1	1
	AF919 Batteria ricaricabile 12V 12Ah (per ALI2450 e AF999PLUS). <i>Rechargeable battery 12V 12Ah (for ALI2450 and AF999PLUS).</i>		86,93	1	1



Attenzione:
è consigliata l'installazione di un limitatore di sovratensione per prevenire danni all'impianto in caso di scariche atmosferiche e sovratensioni degli impianti (vedi apposita sezione del catalogo).

Warning:
the installation of a surge protection device is recommended to prevent damage to the system in the event of atmospheric discharges and overvoltages of the systems (consult specific section of the catalogue).



Antintrusione

Anti-intrusion

Prodotti per ricambistica
Spare parts products

632



Per la disponibilità contattare
la rete commerciale
For availability please
contact sales dept.

	Descrizione <i>Description</i>	Info	€	□	□
per/for AF998EXP	TSINT01 Interfaccia per Touch screen. Permette di collegare i touch screen AVE alla centrale AF998EXP. <i>Interface for AVE touch screen. It allows to connect the anti-intrusion central unit AF998EXP to AVE touch screens.</i>		52,29	1	1
per/for AF996PLUS	AFPC03 Cavo RS232 per programmazione centrale AF996PLUS. Permette la programmazione di tutti i parametri della centrale ed il monitoraggio da PC. <i>RS232 programming cable for AF996PLUS central unit. It allows setting all the parameters of the central unit and the monitoring via a PC.</i>		95,98	1	1
per/for AF996PLUS	AF996TAST Tastiera per centrale AF996PLUS. Montaggio a parete su scatola 3 e 2 moduli o ad incasso su maxi modulo S45. Indicatori a led, assorbimento max 70mA. Dimensioni: 102x125x30mm. <i>Keypad for AF996PLUS central unit. It can be used for wall mounted installation (2 or 3 module boxes) or on the flush mounted S45 maxi module. Led indicators, max current adsorbition 70mA. Dimensions: 102x125x30mm.</i>		105,81	1	1
	AF45339 Chiave elettronica a contatto per lettori AF45B41, AF45341, AF45941 ed inseritori (necessari per la gestione delle centrali AF53904, AF53907, AF997) AF45342, AF45B42, AF441042, AF442042, AF443042. <i>Electronic contact key for AF45B41, AF45341, AF45941 and inserters (necessary for the management of the control panels AF53904, AF53907, AF997) AF45342, AF45B42, AF441042, AF442042, AF443042.</i>		46,43	1	1
	AF45341 Inseritore per chiave elettronica AF45339 - S45 serie Noir. Da abbinare al 45378DF. Non funziona se installato direttamente sulle centrali AF997, AF994, AF53907, AF53904. <i>Electronic key reader - S45 Noir series. To be completed with a 45378DF. It doesn't work with AF997, AF994, AF53907 and AF53904 central units.</i>		41,49	1	10



Per la disponibilità contattare
la rete commerciale
For availability please contact
sales dept.



Disponibilità fino ad
esaurimento scorte
Available until stock out



Prodotto per scatola
rettangolare inglese
Product for British standard
rectangular box

Allarmi tecnici

Technical alarms



Rivelatori di fughe di gas da parete Wall mounted gas detectors

	Descrizione Description	Info	€	<input type="checkbox"/>	<input type="checkbox"/>	633
 <p>RG1-G RG1-M</p>	<p>RG1-G Rivelatore GPL da parete. Alimentazione 230Vca. Uscita con contatto in scambio NA+NC libero da potenziale. Funzione di autodiagnosi attivabile da pulsante frontale. Dimensioni: 156x95x42mm. <i>Wall mounted LPG gas detector. Supply 230Vac. Output with changeover potential free contact NO+NC. With selftest. Dimensions: 156x95x42mm.</i></p>		151,25	1	1	
	<p>RG1-M Rivelatore di gas metano da parete. Caratteristiche come RG1-G. <i>Wall mounted methane gas detector. Technical data see RG1-G.</i></p>		151,25	1	1	

Elettrovalvole per gas Electrovalves for gas

	Descrizione Description	Info	€	<input type="checkbox"/>	<input type="checkbox"/>
 <p>EVG220</p>	<p>EVG220 Elettrovalvola 230Vca - 3/4" - 14VA. <i>Electrovalve 230Vac - 3/4" - 14VA.</i></p>		126,67	1	1

Nota: utilizzare con sensori RG1-G e RG1-M. *Note: to be used with RG1-G and RG1-M.*

La gamma di rivelatori per allarmi tecnici può essere integrata con i dispositivi della gamma Domus Air - Controllo dell'Ambiente
The range of detectors for technical alarms can be integrated with devices from the Domus Air range - Environmental Control



VMC CENTRALIZZATA CON RECUPERO DI CALORE
CENTRALISED HEAT RECOVERY UNIT

TOUCH SCREEN

IGROSTATO /HYGROSTAT

REGOLATORE VELOCITA' /SPEED CONTROLLER

INTERFACCIA ANALOGICA PER VMC
CMV ANALOG INTERFACE

Domusair®

DIVISIONE SICUREZZA
SAFETY-SECURITY

Le dimensioni, salvo diversamente specificato, sono in mm
Dimensions, except where otherwise specified, are in mm

Prodotto per Export
For Export only

Imballo Minimo pcs
Min. Packaging pcs

Imballo Standard pcs
Std. Packaging pcs



Sistemi indirizzati di rivelazione automatica di incendio

Addressed automatic fire detection systems



Vista d'insieme del sistema indirizzato di rivelazione automatica di incendio

Addressed automatic fire detection systems overview

634



AC502

- Centrale indirizzata a 2 loop:
- Ampio display LCD
 - 240 dispositivi per ogni loop
 - 100 zone logiche
 - Corrente del loop di 500mA
 - Gestione da PC tramite connessione USB e LAN
 - Certificazioni CPR della centrale e di tutte le periferiche associate.

Addressed central unit with 2 loops:

- Wide LCD display
- 240 devices for each loop
- 100 logical zones
- Loop current of 500mA
- Control via PC with USB or LAN connection
- CPR approval of the central unit and all associated peripherals.



ACINT01

Interfaccia LAN per centrali antincendio serie "500".

LAN interface for series "500" central units.

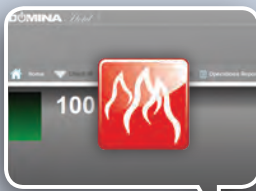

domina Pro
Hotel Management System

ARM Bus



I sistemi di rivelazione automatica di incendio possono essere **INTEGRATI CON LA GESTIONE ALBERGHIERA "DOMINA HOTEL"**.

The automatic fire detection systems can be **INTEGRATED WITH THE HOTEL AUTOMATION SYSTEM "DOMINA HOTEL"**.

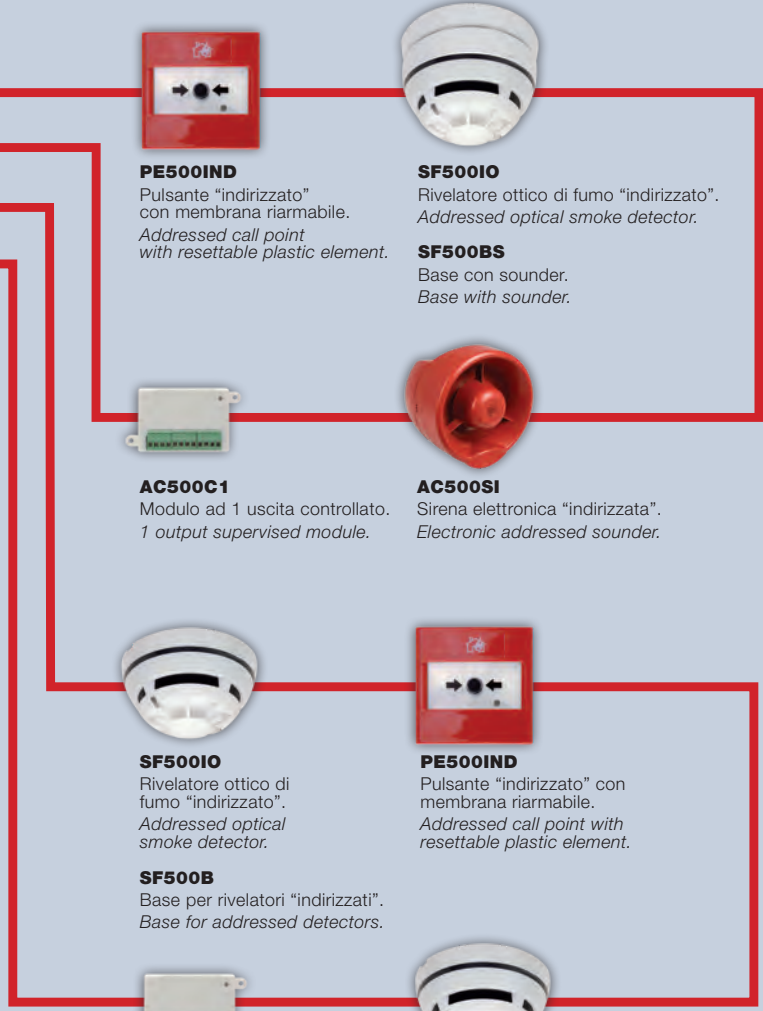

PE500IND

Pulsante "indirizzato" con membrana riarmabile. Addressed call point with resettable plastic element.

SF500IO

Rivelatore ottico di fumo "indirizzato". Addressed optical smoke detector.

SF500BS

Base con sounder. Base with sounder.

AC500C1

Modulo ad 1 uscita controllato. 1 output supervised module.

AC500SI

Sirena elettronica "indirizzata". Electronic addressed sounder.

SF500IO

Rivelatore ottico di fumo "indirizzato". Addressed optical smoke detector.

PE500IND

Pulsante "indirizzato" con membrana riarmabile. Addressed call point with resettable plastic element.

SF500B

Base per rivelatori "indirizzati". Base for addressed detectors.

AC500C1R

Modulo di uscita a rele'. Output module with relay.

SF500IT

Rivelatore termovelocimetrico "indirizzato". Addressed thermal detector.

SF500B

Base per rivelatori "indirizzati". Base for addressed detectors.

domina Pro
Call System

I sistemi di rivelazione automatica di incendio possono essere **INTEGRATI CON LA DOMOTICA PER RSA**

The automatic fire detection systems can be **INTEGRATED WITH THE NURSING HOME AUTOMATION.**



Sistemi convenzionali di rivelazione automatica di incendio

Conventional automatic fire detection systems

domina Pro
Fire Detection System

a
ave

Vista d'insieme del sistema convenzionale di rivelazione automatica di incendio

Conventional automatic fire detection systems overview

635

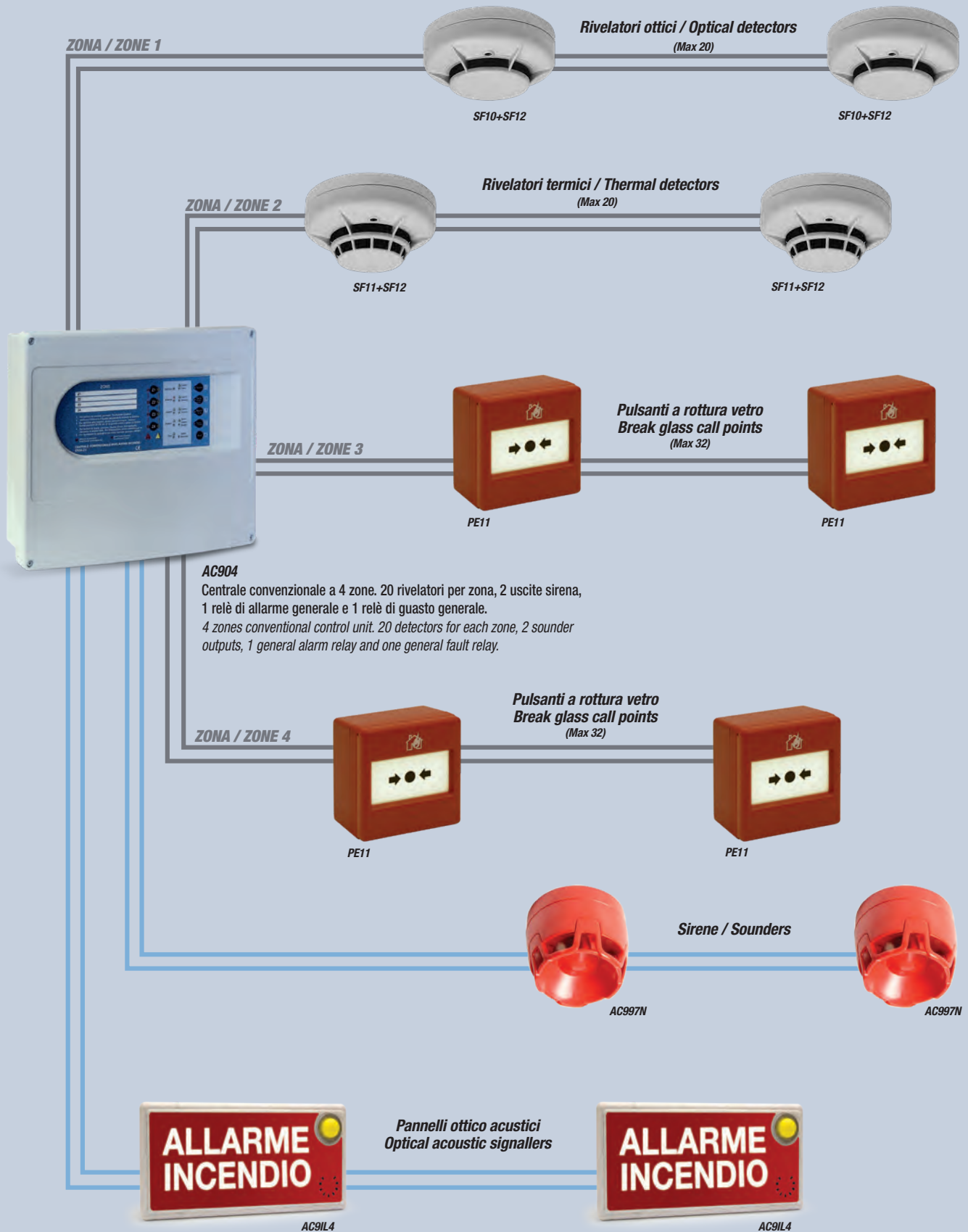

DIVISIONE SICUREZZA
SAFETY-SECURITY





Sistemi di rivelazione automatica di incendio



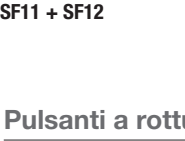

Automatic fire detection systems

Sistemi convenzionali Conventional systems

636

	Descrizione <i>Description</i>	Info	€	□	□
	AC904 Centrale convenzionale a 4 zone. n.20 rivelatori per zona, n.2 uscite sirena, n.1 relè di allarme generale e un relè di guasto generale. Da completare con n.2 batterie AF912 (12V 6,5Ah). Dimensioni: 380x320x110mm. <i>4 zones conventional control unit. n.20 detectors for each zone, n.2 sounder outputs, n.1 general alarm relay and one general fault relay. To be completed with n.2 AF912 batteries (12V 6,5Ah). Dimensions: 380x320x110mm.</i>		581,11	1	1
AC904					
	SF10 Rivelatore ottico convenzionale per centrale AC904. <i>Conventional optical smoke detector for AC904 central unit.</i>		70,20	1	1
SF10 + SF12					
	SF11 Rivelatore termovelocimetrico convenzionale per centrale AC904. <i>Conventional rate of rise heat detector for AC904 central unit.</i>		60,75	1	1
SF11 + SF12					
	SF12 Base per rivelatori convenzionali SF10 e SF11. <i>Base for SF10 and SF11 conventional detectors.</i>		18,72	1	1

Pulsanti a rottura vetro *Break glass call point*

	Descrizione <i>Description</i>	Info	€	□	□
	PE10 Pulsante manuale a rottura vetro per sistemi convenzionali. n.1 contatto in scambio da 24Vcc/3A. Grado di protezione IP66. Dimensioni: 87x87x59mm <i>Break glass call point for conventional alarm activation. n.1 switching contact 24Vdc/3A. IP66 protection degree. Dimensions: 87x87x59mm</i>		132,13	1	1
PE10					
	PE11 Pulsante manuale a rottura vetro per sistemi convenzionali. n.1 contatto in scambio da 24Vcc/3A. Grado di protezione IP42. Fornito con membrana riarmabile. Dimensioni: 87x87x55mm <i>Break glass call point for conventional alarm activation. n.1 switching contact 24Vdc/3A. IP42 protection degree. Supplied with resettable device. Dimensions: 87x87x55mm</i>		40,17	1	1
PE11					
	PE90 Martelletto a catena per PE08. <i>Hammer with chain for PE08.</i>		19,63	1	1
PE90					
	PE96 Vetrino di ricambio per PE10 e PE11. <i>Spare glass for PE10 and PE11.</i>		4,88	10	10
PE96					



Per la disponibilità contattare la rete commerciale
For availability please contact sales dept.









Disponibilità fino ad esaurimento scorte
Available until stock out

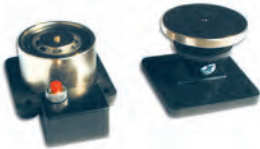

Prodotto per scatola rettangolare inglese
Product for British standard rectangular box

Avvisatori d'allarme e Accessori
Alarm devices and Accessories

	Descrizione <i>Description</i>	Info	€	□	□
	AC9RP1 Indicatore ottico fuoriporta per rivelatore incendio. <i>Optical signal repeater for fire detector.</i>		32,73	1	1
AC9RP1					
	AC9IL4 Avvisatore ottico acustico per segnalazione d'allarme incendio. Alimentazione 24Vcc. Assorbimento 130mA a 24Vcc. Parte ottica realizzata con LED ad alta luminosità. Grado di protezione IP54. Conforme alle normative EN 54-3 ed EN 54-23. Dimensioni: 365x175x55mm. <i>Optical acoustic signaller for fire alarm signalling. 24Vdc power supply. Consumption 130mA at 24Vdc. Optical part made with a high-brightness LED. IP54 protection degree. Standard compliance: EN 54-3 and EN 54-23. Dimensions: 365x175x55mm.</i>		190,92	1	1
AC9IL4					
	AC997N Sirena elettronica fornita con base. <i>Electronic sounder with base included.</i>		68,88	1	1
AC997N					
	AC997SN Sirena elettronica fornita con base. IP65. <i>Electronic sounder with base included. IP65.</i>		69,12	1	1
AC997SN					
	ACMAG01 Elettromagnete per porta tagliafuoco - forza di ritenuta 50Kg - pulsante di sblocco. <i>Electromagnet for fire doors retention 50kg - release button.</i>		92,86	1	1
ACMAG01					
	ALI2450N Alimentatore ausiliario 24Vdc 5A per sistemi di rivelazione incendio. N.2 batterie 12V 18Ah fornite a corredo. Dimensioni (LxHxP): 400,5x355x9,5mm. <i>Auxiliary power supply 24Vdc 5A for fire detection systems. N.2 12V 18Ah batteries supplied. Dimensions (WxHxD): 400.5x355x9.5mm.</i>		920,16	1	1
ALI2450N					

 **Attenzione:**
è consigliata l'installazione di un limitatore di sovratensione per prevenire danni all'impianto in caso di scariche atmosferiche e sovratensioni degli impianti (vedi apposita sezione del catalogo).
Warning:
the installation of a surge protection device is recommended to prevent damage to the system in the event of atmospheric discharges and overvoltages of the systems (consult specific section of the catalogue).



Sistemi di rivelazione automatica di incendio

Automatic fire detection systems

Sistema indirizzato con centrali da 1 a 4 loop
Addressed system with 1-4 loops control panel

638

Descrizione Description

Info

€

□

□



AC501

AC501

Centrale rivelazione incendio ad 1 loop con capacità di n.240 dispositivi.
N.100 zone logiche, corrente di loop: 500mA. Programmazione tramite porta USB.
Da completare con n.2 batterie AF912. Dimensioni: 420x360x85mm.
*One loop fire detection control unit with the possibility of connecting n.240 detectors.
N.100 logical zones, loop current of 500mA. Programmable via USB.
To be completed with n.2 batteries (AF912). Dimensions: 420x360x85mm.*

1754,72 1 1



AC502

AC502

Centrale rivelazione incendio a 2 loop. Possibilità di connettere n.240 dispositivi per ciascun loop. N.100 zone logiche, corrente di loop: 500mA. Programmazione tramite porta USB. Da completare con n.2 batterie AF912. Dimensioni: 420x360x85mm.
N.2 loops fire detection control unit. Possibility of connecting n.240 detectors for each loop. N.100 logical zones, loop current of 500mA. Programmable via USB. To be completed with n.2 batteries (AF912). Dimensions: 420x360x85mm.

2256,58 1 1



ACINT01

ACINT01

Interfaccia LAN per centrali antincendio serie "500". Permette l'integrazione con i sistemi di gestione alberghiera "Domina hotel" e i sistemi domotici residenziali "Domina Plus".
LAN interface for series "500" control units. It allows the integration with the hotel automation systems "Domina Hotel" and the home automation systems "Domina Plus".

732,70 1 1

AC500P

Unità di programmazione serie "500". Permette la programmazione di tutte le periferiche della serie "500" (moduli, rivelatori, pulsanti, sirene).
Programming unit for series "500". It allows you to program all the devices of the "500" series (modules, detectors, push-buttons, sounders).

376,25 1 1

AC500PRA

Pannello remoto attivo per centrali A501 e AC502. E' sufficiente l'utilizzo di una sola interfaccia AC500RS485 per uno o più pannelli remoti.
Remote control and display panel for AC501 and AC502 central unit. It is enough to use a single AC500RS485 interface for one or more remote panels.

1348,78 1 1

AC500RS485

Interfaccia RS485 per centrali AC501 e AC502. Permette la creazione di una rete RS485 in cui è possibile collegare più centrali tra loro (ogni centrale necessita di un'interfaccia AC500RS485) o collegare uno o più pannelli remoti.
RS485 interface for AC501 and AC502 central units. It allows the creation of an RS485 network in which it is possible to connect multiple control units (each control unit requires an AC500RS485 interface) or connect one or more remote panels.

444,55 1 1



AC500P

Nota: programmare i dispositivi con il programmatore AC500P prima di installarli.
Note: please program the devices via the programming unit AC500P before connecting them.

Service Service

Descrizione Description



SERVICE

Il codice SERVICE equivale ad un'ora di assistenza tecnica e/o attivazione impianto per tutti i prodotti AVE, ed in particolare per i prodotti appartenenti ai sistemi antintrusione, rivelazione automatica d'incendio, domotica e gestione alberghiera. Per informazioni commerciali contattare la rete vendita AVE.
Il SERVICE è valido solo per sistemi e prodotti installati sul territorio nazionale italiano.
The SERVICE code is equivalent to one hour of technical assistance and / or activation facility for all products made by AVE, and especially for products belonging to anti-burglar systems, fire detection systems, home automation and hotel management systems.
For sales information please contact the sales department of AVE.
The SERVICE is available only for systems and products installed in Italy.



Per la disponibilità contattare la rete commerciale
For availability please contact sales dept.











Disponibilità fino ad esaurimento scorte
Available until stock out



Prodotto per scatola rettangolare inglese
Product for British standard rectangular box

Sistema indirizzato: periferiche filari
Addressed system: wired devices

639

	Descrizione <i>Description</i>	Info	€	<input type="checkbox"/>	<input type="checkbox"/>
	SF500IO Rivelatore ottico di fumo ("indirizzato") con isolatore, per centrali AC501 e AC502. <i>Addressed optical smoke detector with insulator for AC501, AC502 central units.</i>		82,10	1	1
SF500IO SF500BS					
	SF500IT Rivelatore termovelocimetrico ("indirizzato") con isolatore, per centrali AC501 e AC502. <i>Addressed rate of rise heat detector with insulator for AC501 and AC502 central units.</i>		89,12	1	1
SF500IT					
	SF500B Base per rivelatori SF500IO e SF500IT. <i>Base for SF500IO and SF500IT detectors.</i>		10,16	1	1
SF500B					
	AC500M1 Modulo indirizzato ad un ingresso con isolatore per centrali AC501 e AC502. <i>One input addressed module with insulator for AC501 and AC502 central units.</i>		111,69	1	1
AC500M1 AC500C1 AC500C1R					
	AC500C1 Modulo indirizzato ad un'uscita controllata con isolatore per centrali AC501 e AC502. <i>One supervised output addressed module with insulator for AC501 and AC502 central units.</i>		109,91	1	1
AC500C1R					
	PE500IND Pulsante manuale indirizzato con membrana riarmabile, completo di isolatore di corto circuito. Per centrali AC501 e AC502. Dimensioni: 90x90x60 mm. <i>Addressed glass call point, with resettable plastic element and short-circuit insulator included. For AC501 and AC502 central units. Dimensions: 90x90x60 mm.</i>		93,78	1	1
AC500M1 AC500C1 AC500C1R					
	AC500SI Sirena elettronica indirizzata per centrali AC501 e AC502. Pressione sonora 100dB, assorbimento 8mA. Dimensioni: 125x130x95mm. <i>Electronic addressed sounder for AC501 and AC502 central units. Sound pressure 100dB, Consumption 8mA. Dimensions: 125x130x95mm.</i>		181,38	1	1
AC500SI					
	SF500BS Base con sounder per centrali AC501 e AC502. Permette il montaggio di un sensore SF500IO o SF500IT. <i>Base with sounder for AC501 and AC502 central units. It allows you to mount a detector SF500IO or SF500IT on it.</i>		103,54	1	1
PE500IND					



Attenzione:
 è consigliata l'installazione di un limitatore di sovratensione per prevenire danni all'impianto in caso di scariche atmosferiche e sovratensioni degli impianti (vedi apposita sezione del catalogo).
Warning:
the installation of a surge protection device is recommended to prevent damage to the system in the event of atmospheric discharges and overvoltages of the systems (consult specific section of the catalogue).



Sistemi di rivelazione automatica di incendio

Automatic fire detection systems









Articoli speciali (disponibili a commessa)
Special items (available upon request)



Per la disponibilità contattare
la rete commerciale
For availability please
contact sales dept.

640

Rivelatori e dispositivi indirizzati speciali per centrali AC501 e AC502 *Special addressed detectors and devices for AC501 and AC502 central units*

01		Rivelatore ottico-termico per centrali AC501 e AC502. Necessita di base SF500B. <i>Optical-thermal detector for AC501 and AC502 central units. It can be used only together the SF500B base.</i>
02		Rivelatore termico radio per centrali AC501 e AC502. Completo di base. Necessita di traslatore radio AC500RR. <i>Wireless thermal detector for AC501 and AC502 central units. Base included. It can be used only together the wireless translator AC500RR.</i>
03		Pulsante manuale indirizzato IP67 con membrana riarmabile per centrali analogiche. Completo di isolatore di corto circuito. Per centrali AC501 e AC502. Dimensioni: 119x128x62mm. <i>Addressed IP67 glass call point for analogic control unit, with resettable plastic element and short-circuit insulator included. For AC501 and AC502 central units. Dimensions: 119x128x62mm.</i>
04		Cover trasparente di protezione per pulsanti PE500IND. Permette di prevenire eventuali falsi allarmi. <i>Transparent protection cover for PE500IND call points. It is a protective cover to help stop malicious or accidental false fire alarms.</i>
05		Indicatore ottico fuoriporta per centrali AC501 e AC502. Dispositivo indirizzabile e programmabile. Collegamento direttamente su loop. Assorbimento 5mA. Dimensioni: 80x80x27mm. <i>Optical signal repeater for AC501 and AC502 central units. It is addressed and programmable and it has to be connected directly on the loop. Absorption:5mA. Dimensions: 80x80x27mm.</i>
06		Camera di analisi per condotte comprensiva di base SF500B. Da completare con rivelatore serie 500 (ad esempio SF500IO) e tubo di campionamento. Dimensioni: 279x165x103mm. <i>Analysis chamber for conduct with base SF500B included. To be completed with a detector of 500 series (for example SF500IO) and a sampling tube. Dimensions: 279x165x103mm.</i>
07		Tubo di campionamento metallico per camera di analisi. Lunghezza: 0,6m. <i>Metal sampling tube for the analysis chamber. Length: 0,6m.</i>
08		Tubo di campionamento metallico per camera di analisi. Lunghezza: 1,5m. <i>Metal sampling tube for the analysis chamber. Length: 1,5m.</i>
09		Sirena elettronica indirizzata con lampeggiante per centrali AC501 e AC502. Assorbimento: 25mA. Pressione acustica: max. 100dB a 1m. Numero di toni: 32. Dimensioni: 130x130x100mm. <i>Addressed electronic sounder with flashing led for AC501 and AC502 central units. Absorption: 25mA. Sound pressure: max. 100dB at 1m. Number of tones: 32. Dimensions: 130x130x100mm.</i>



Per la disponibilità contattare
la rete commerciale
For availability please contact
sales dept.



Disponibilità fino ad
esaurimento scorte
Available until stock out



Prodotto per scatola
rettangolare inglese
Product for British standard
rectangular box



Per la disponibilità contattare
la rete commerciale
For availability please
contact sales dept.



Sirene convenzionali *Conventional sounders*

10



Sirena convenzionale autoalimentata per esterno con lampeggiante led. Pressione acustica max. 102dB a 1m. Dotata di funzione di autodiagnostica. Di colore rosso. Alimentazione 15-33Vcc. Temperatura di funzionamento da -25°C a +55°C. Grado di protezione IP44, necessita di batteria AF911 (non inclusa). Dimensioni: 330x210x115mm.

Conventional self-powered outdoor siren with flashing LED. Max sound pressure 102dB at 1m. Equipped with self-diagnosis function. Red colour. Power supply: 15-33Vdc. Operating temperature from -25 °C to + 55 °C. Degree of IP44, it requires AF911 battery (not included). Dimensions: 330x210x115mm.

Rivelatori convenzionali speciali *Special conventional detectors*

11



Cavo termosensibile speciale costituito da due conduttori che alla temperatura prefissata di 68°C segnalano l'allarme a mezzo di corto circuito. Collegabile a centrale indirizzata mediante modulo di ingresso.

Thermosensitive cable made by two conductors that at the temperature of 68 °C indicate the alarm via a short-circuiting. It can be used on addressed central unit via an input module.

Rivelatori lineari convenzionali *Linear conventional detectors*

12



Rivelatore lineare di fumo costituito da due parti, una parte trasmittente TX ed una parte ricevente RX. Raggio di protezione compreso tra 5 e 100m. Assorbimento a riposo 51mA, in allarme 70mA. Fornito con snodi. Dimensioni del corpo del rivelatore: 80x150x80mm; dimensioni staffa: 80x60mm; Ø 65mm.

Beam smoke detectors made up of two parts: a transmitting device (TX) and a receiving one (RX). The detector can be used for distances between 5 and 100m. Stand-by consumption: 51mA, alarm condition consumption: 70mA. Joints included. Dimensions of the detectors: 80x150x80mm. Dimension of the joints: 80x60mm; Ø 65mm.

13



Rivelatore lineare di fumo a riflessione, composto da un'unica unità ottica (TRX) e da un riflettore. Raggio di protezione compreso tra 2 e 50m. Assorbimento a riposo 39mA, in allarme 52mA. Dimensioni (con snodo): 103x103x119mm.

Beam smoke detectors made up of two parts: a transmitting/receiving device (TRX) and reflectors. The detector can be used for distances between 2 and 50m. Stand-by consumption: 39mA, alarm condition consumption: 52mA. Dimensions (with joint): 103x103x119mm.

14



Snodo per rivelatore lineare a riflessione (articolo n.2).

Joint for reflective beam detector (item n.2).

Rivelatori di gas *Gas detectors*

15

CH₄

Rivelatore catalitico per gas metano IP55. 3 uscite a relè: contatti N.C. / C. / N.A. liberi da potenziale (1A resistivo@30 Vcc). Assorbimento a riposo di 70mA ed in allarme di 90mA.

Catalytic detector for natural gas. IP55. 3 relay outputs: N.C./ C. / N.O. Potential free contacts (1A resistive@30 Vdc). Standby absorption 70mA and 90mA in alarm condition.

16



Scheda n.3 relè per rivelatori di gas con uscita 4-20mA. Le 3 uscite sono configurabili tramite jumper. Dotata di cavo flat per l'inserimento nell'apposito connettore presente sulla scheda base del rivelatore. Portata relè 1A@24Vcc (carico resistivo).

Electronic board with n.3 relays for gas detectors with 4-20mA output. The 3 outputs can be configured via jumpers. It is equipped with a flat cable for the connection on the main board of the gas detector. Output relay 1A@24Vdc (resistive load).



Sistemi di rivelazione automatica di incendio

Automatic fire detection systems

Articoli speciali (disponibili a commessa)



Special items (available upon request)



Per la disponibilità contattare la rete commerciale
For availability please contact sales dept.

642

Rivelatori di gas Gas detectors

17	 H₂	<p>Rivelatore catalitico di idrogeno 4-20mA, adatto ad installazioni in ambiente classificato AD-PE. Uscita proporzionale 4-20mA. Collegabile su centrali indirizzate tramite scheda relè e apposito modulo. Possibile utilizzo con scheda relè su centrali a doppia soglia con preallarme a 10mA ed allarme a 20mA. Tensione di funzionamento 12-24Vcc. Assorbimento 90mA. Temperatura di funzionamento da -10°C a +55°C. Umidità relativa sino a 90%. Certificazione ATEX CESA per ambienti AD-PE. Dimensioni: 105x200x110mm.</p> <p><i>Catalytic hydrogen detector 4-20mA, suitable for installation in environments classified as AD-PE. Proportional output 4-20mA. It can be used on addressed central unit via a relay board and an input module. You can use with relay board of the central double threshold with early warning to 10mA and 20mA alarm. Operating voltage: 12-24Vdc. Absorption: 90mA. Operating temperature from -10°C to +55°C. Relative humidity up to 90%. It is compliant to ATEX CESA standards for environments classified as AD-PE. Dimensions: 105x200x110mm.</i></p>
18	 CH₄	<p>Rivelatore catalitico di metano 4-20mA, adatto ad installazioni in ambiente classificato AD-PE. Uscita proporzionale 4-20mA. Collegabile su centrali indirizzate a mezzo d'apposito modulo. Possibile utilizzo con scheda relè su centrali a doppia soglia con preallarme a 10mA ed allarme a 20mA. Tensione di funzionamento 12-24Vcc. Assorbimento 90mA. Temperatura di funzionamento da -10°C a +55°C. Umidità relativa sino a 90%. Certificazione ATEX CESA per ambienti AD-PE. Dimensioni: 105x200x110mm.</p> <p><i>Catalytic methane 4-20mA detector, suitable for installations in the room classified AD-PE. 4-20mA output proportional. It can be used on addressed central unit via a relay board and an input module. You can use with relay board of the central double threshold with early warning to 10mA and 20mA alarm. Operating voltage: 12-24Vdc. 90mA absorption. Operating temperature from -10°C to +55°C. Relative humidity up to 90%. ATEX CESA for environments AD-PE. Dimensions: 105x200x110mm.</i></p>
19	 CH₄	<p>Rivelatore di metano 4-20mA in contenitore antipolvere. Il sensore di tipo catalitico garantisce le segnalazioni di allarme tramite uscita proporzionale 4-20mA. Collegabile su centrali indirizzate a mezzo d'apposito modulo. Possibile utilizzo con scheda relè su centrali a doppia soglia con preallarme a 10mA ed allarme a 20mA. Tensione di funzionamento 12-24Vcc. Assorbimento 90mA. Temperatura di funzionamento da -10°C a +55°C. Umidità relativa sino a 90%. Grado di protezione IP55. Dimensioni: 106x180x62mm.</p> <p><i>Methane detector 4-20 mA dust container. The catalytic sensor provides alarm messages via proportional 4-20mA output. It can be used on addressed central unit via a relay board and an input module. You can use with relay board of the central double threshold with early warning to 10mA and 20mA alarm. Operating voltage: 12-24Vdc. 90mA absorption. Operating temperature from -10°C to + 55°C. Relative humidity up to 90%. Degree of protection IP55. Dimensions: 106x180x62mm.</i></p>
20	 GPL	<p>Rivelatore di GPL 4-20mA in contenitore antipolvere. Il sensore di tipo catalitico garantisce le segnalazioni di allarme tramite uscita proporzionale 4-20mA. Collegabile su centrali indirizzate a mezzo d'apposito modulo. Possibile utilizzo con scheda relè su centrali a doppia soglia con preallarme a 10mA ed allarme a 20mA. Tensione di funzionamento 12-24Vcc. Assorbimento 90mA. Temperatura di funzionamento da -10°C a +55°C. Umidità relativa sino a 90%. Grado di protezione IP55. Dimensioni: 106x180x62mm.</p> <p><i>LPG 4-20mA detector in dustproof box. The catalytic sensor provides alarm messages via proportional 4-20mA output. It can be used on addressed central unit via a relay board and an input module. You can use with relay board of the central double threshold with early warning to 10mA and 20mA alarm. Operating voltage: 12-24Vdc. Absorption: 90mA. Operating temperature from -10°C to + 55°C. Relative humidity up to 90%. Degree of protection: IP55. Dimensions: 106x180x62mm.</i></p>



Per la disponibilità contattare la rete commerciale
For availability please contact sales dept.



Disponibilità fino ad esaurimento scorte
Available until stock out



Prodotto per scatola rettangolare inglese
Product for British standard rectangular box

Prodotti per ricambistica
Spare parts products

643



SF910



SF91T



AC9C1-IS
AC9M1-IS



PE09IND

Descrizione Description	Info	€	<input type="checkbox"/>	<input type="checkbox"/>
AC9M1-IS Modulo indirizzabile ad un ingresso per centrali AC921, AC922, AC924. <i>One input addressed module for AC921, AC922, AC924 detector units.</i>		257,33	1	1
SF910T Rivelatore ottico/termico indirizzato per centrali AC921, AC922, AC924. <i>Addressed smoke/thermal detector for AC921, AC922, AC924 central units.</i>		189,74	1	1
SF910 Rivelatore ottico di fumo indirizzato, per centrali AC921, AC922, AC924. <i>Addressed optical smoke detector for AC921, AC922, AC924 central units.</i>		286,42	1	1
SF91T Rivelatore termovelocimetrico indirizzato, per centrali AC921, AC922, AC924. <i>Addressed rate of rise heat detector for AC921, AC922, AC924 central units.</i>		178,54	1	1
SF9B Base per rivelatori SF910, SF91T, SF910T. <i>Base for SF910, SF910T, SF91T detectors.</i>		28,23	1	1
AC9C1-IS Modulo indirizzabile ad un'uscita con isolatore per centrali AC921, AC922, AC924. <i>One output addressed module with isolation for AC921, AC922, AC924 central units.</i>		270,88	1	1
PE09IND Pulsante manuale indirizzato a rottura vetro per centrali analogiche completo di isolatore di corto circuito. Membrana riarmabile fornibile a richiesta. <i>Addressed break glass call point for analogic central unit, with short-circuit insulator included. Available with resettable membrane (upon request).</i>		275,69	1	1

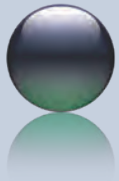

Apparecchiature per Emergenza

Emergency Devices

Lampade anti black-out e di emergenza

Anti black-out and emergency lights

644

Caratteristiche Tecniche Technical Features

442089

Scatole per installazione
Installation boxes

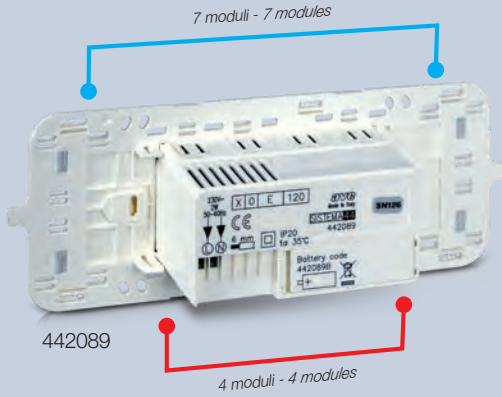

Scatole standard italiano
Italian standard boxes

Schema di collegamento
Wiring diagram

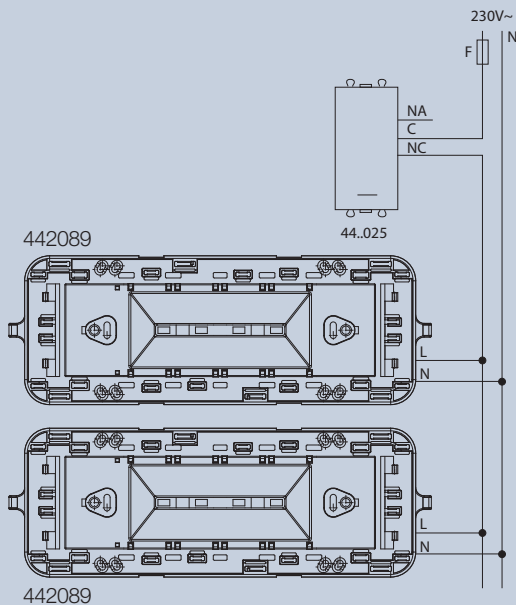

F: Fusibile / Fuse

Curva fotometrica in emergenza
Emergency photometric diagram

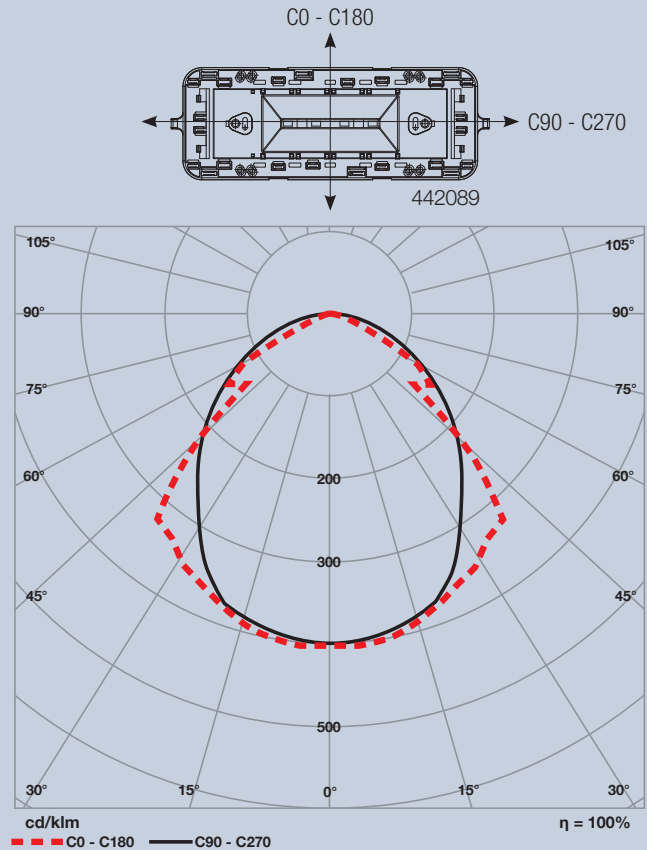

Per la disponibilità contattare la rete commerciale
For availability please contact sales dept.



Disponibilità fino ad esaurimento scorte
Available until stock out



Prodotto per scatola rettangolare inglese
Product for British standard rectangular box

Descrizione Description		Info	€		
		□ 446086 ■ 445086 Lampada anti black-out estraibile portatile - completa di base di ricarica e di batterie ricaricabili e sostituibili - lampada: led colore bianco ad alta efficienza interruttore frontale per spegnimento in assenza tensione di rete - tempo di ricarica 36h - autonomia 3h circa - alimentazione 110÷230 V~ - serie Whitek e Tekla - 2 mod. S44 <i>Anti black out removable portable light - with recharging base and interchangeable and rechargeable batteries - lamp: high efficiency white led - front switch in case of power failure 36h recharge time - 3h endurance - 110÷230 V~ power supply - Whitek and Tekla series - 2 mod. S44</i>	107,48	1	1
		□ 441086 ■ 449086 Come sopra - serie Domus e Class. <i>As above - Domus and Class series.</i>	106,53	1	1
		■ 442086 ■ 443086 Come sopra - serie Life e Allumia. <i>As above - Life and Allumia series.</i>	■ 144,85 1 1 ■ 122,98 1 1		
		45786B Batteria (4x1,2)V - 80mAh, di ricambio per lampada anti black out 44..086 <i>Spare battery for 44..086 anti black out portable light (4x1,2)V - 80mAh</i>	14,82	1	1
		442089 Lampada di emergenza a LED bianchi ad alta efficienza 230V~ 50/60Hz - SE - batteria ricaricabile e sostituibile 3,7V 700mAh - tempo di ricarica 12h - autonomia 2h autodiagnosi permanente della funzionalità della batteria con segnalazione luminosa in caso di anomalia - flusso luminoso 90 lumen - completa di armatura MULTICOMPATIBILE 6/7 moduli - installabile sia in scatole da incasso standard 6/7 moduli sia in scatole 4 moduli - da completare con placche standard 7 moduli S44 di Ave o con placche di altri costruttori (Bticino Livinglight, Bticino Living International, Bticino Light, Vimar Eikon, Vimar Plana) - 4x7 mod. <i>Emergency light with a white high-efficiency LED 230V ~ 50 / 60Hz - N/M - Rechargeable and changeable battery: 3.7V 700mAh - Recharge time: 12h - 2h of endurance - permanent self-diagnosis of the battery functionality with warning light in case of failures - luminous flux 90 lumen - complete with MULTI-COMPATIBLE 6/7 modules frames - installable in standard flush mounted boxes 6/7 modules or in 4 modules boxes - to be completed with standard front plates 7 modules Ave S44 or plates from other manufacturers (Bticino Livinglight, Bticino Living International, Bticino Light, Vimar Eikon, Vimar Plana) - 4x7 mod.</i>	109,97	1	1
		442089B Batteria Li-Ion 3,7 V 700 mAh di ricambio per lampada d'emergenza 442089. <i>Spare battery Li-Ion 3,7 V 700 mAh for emergency light 442089.</i>	32,15	1	1

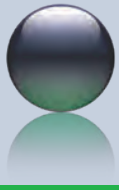

Apparecchiature per Emergenza

Emergency Devices

PE08 Quadretto a rottura vetro per comando di emergenza IP66

PE08 Breaking glass emergency panel IP66

646

Caratteristiche Tecniche Technical Features

Azionamento Operation

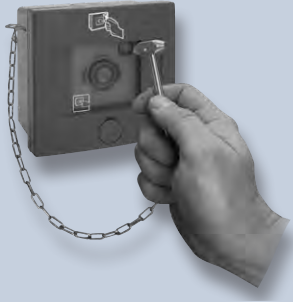

Azionamento automatico alla rottura vetro (una manovra)

Automatic start upon breaking glass
(one action)



Azionamento manuale dopo la rottura del vetro (due manovre)

Manual start after glass breaking (two actions)

Possibilità d'installazione Installation possibilities

Installazione da parete IP66 con scatola fornita di serie

Wall mounted installation IP66 via a special box supplied with the panel

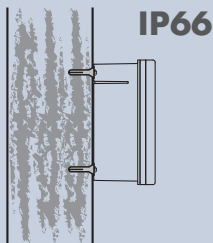

Installazione da incasso IP66 con scatola fornita di serie

Flush mounted installation IP66 via a special box supplied with the panel

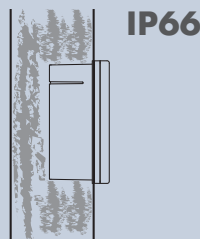

Installazione da parete IP40 su scatola AVE 2503MG

Flush mounted installation IP40 on 2503MG AVE box

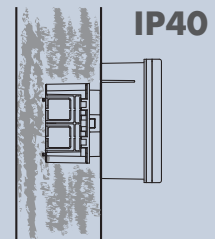

ESEMPI di COLLEGAMENTO Dispositivo di sgancio a lancio di corrente WIRING EXAMPLE Disconnecting device

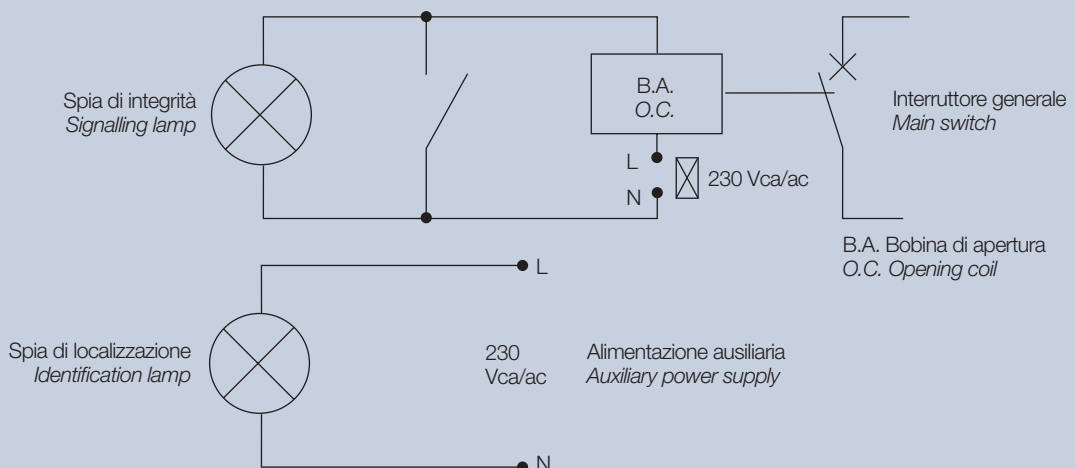

Per la disponibilità contattare la rete commerciale
For availability please contact sales dept.







Disponibilità fino ad esaurimento scorte
Available until stock out



Prodotto per scatola rettangolare inglese
Product for British standard rectangular box

Quadri d'emergenza da parete IP55 e IP66 in materiale plastico IP55 and IP66 plastic material wall mounted emergency enclosures

		Descrizione Description	Info	€	□	□
		Q5505ER Centralino emergenza rosso RAL 3020 completo di barra DIN - 5 mod. DIN - vetro frangibile - serratura con chiave metallica - dimensioni: 157x185x100mm. <i>RAL 3020 red emergency enclosure provided with DIN bar - 5 DIN mod. - breakable glass - lock with metallic key - dimensions: 157x185x100mm.</i>		69,53	1	15
		Q025 Centralino emergenza rosso RAL 3020 completo di barra DIN - 8 mod. DIN - vetro frangibile - serratura con chiave metallica - dimensioni: 217x185x100mm. <i>RAL 3020 red emergency enclosure provided with DIN bar - 8 DIN mod. - breakable glass - lock with metallic key - dimensions: 217x185x100mm.</i>		74,54	1	10
		PE08 Quadretto a rottura vetro per comando di emergenza IP66. Contatti: 1NA + 1NC da 10A/250Vca. Possibilità di predisporre il funzionamento per: azionamento automatico alla rottura vetro (una manovra) - azionamento manuale dopo la rottura del vetro (due manovre). Da completare con martelletto PE90. Dimensioni: 110x110x57mm. <i>Breaking glass emergency panel IP66. 1NO + 1NC 10A/250Vac contacts. Possibility of setting the operation for: automatic start upon breaking glass (one action) manual start after breaking glass (two actions). To be completed with hammer PE90. Dimensions: 110x110x57mm.</i>		49,02	1	1
		PE90 Martelletto a catena per PE03, PE04 e PE08. <i>Hammer with chain for PE03, PE04 and PE08.</i>		19,63	1	1
		PE95 Vetrino di ricambio per PE08. <i>Spare glass for PE08.</i>		5,61	10	10

Quadri da incasso IP40 in materiale plastico IP40 plastic material flush mounted enclosures

		Descrizione Description	Info	€	□	□
		53Q20N Coperchio grigio RAL 7035 completo di barra DIN - vetro frangibile - 4 mod. DIN da installare con scatola BL03P - dimensioni: 109x136x38mm. <i>RAL 7035 cover provided with DIN bar - breakable glass - 4 DIN mod. to be used with BL03P boxes - dimensions: 109x136x38mm.</i>		36,88	1	2
		Q021 Serratura con chiave unificata metallica per quadri 45Q20N - 53Q20N. <i>Metal lock with unified key for 45Q20N - 53Q20N.</i>		11,65	1	1

Quadretti da incasso per serie civili S45 in materiale plastico Plastic material flush mounted enclosures for System 45 wiring devices

		Descrizione Description	Info	€	□	□
		45Q20N Quadretto con chiavistello e vetro frangibile per comando di emergenza capacità 2 mod. Sistema 45 - RAL 7035. <i>Emergency control panel with door latch and breakable glass - 2 modules System 45 - RAL 7035.</i>		25,22	1	6
		Q021 Serratura con chiave unificata metallica per quadri 45Q20N - 53Q20N. <i>Metal lock with unified key for 45Q20N - 53Q20N.</i>		11,65	1	1

Accessori per quadretti di emergenza Accessories for emergency enclosures

		Descrizione Description	Info	€	□	□
		45105R Pulsante di emergenza rosso 1P 10A NA+NC - 2 mod. Sistema 45. <i>NO+NC 10A 1 way single pole emergency pushbutton - red - 2 modules System 45.</i>		14,74	1	6

Le dimensioni, salvo diversamente specificato, sono in mm
Dimensions, except where otherwise specified, are in mm

△ Prodotto per Export
For Export only

□ Imballo Minimo pcs
Min. Packaging pcs

□ Imballo Standard pcs
Std. Packaging pcs